

# E N D E R E S

QUALITY FORGED HAND TOOLS



Updated 2013



**EnderesTools**  
Quality Forged Hand Tools For a Lifetime

<b>SCREWDRIVERS</b> . . . . .	3
Multi-Bit Screwdrivers . . . . .	4
Instructions on Private Labeling-SCREWDRIVERS AND BARS . . . . .	6
Tack Pullers . . . . .	7
Fixed-Blade Screwdrivers . . . . .	7-8
Offset Screwdrivers . . . . .	7-8
<b>POWER BITS</b>	
"Fit All" Power Bits . . . . .	9-11
<b>COLD CHISELS</b> . . . . .	13
<b>MASON TOOLS</b> . . . . .	15
Brick Sets . . . . .	16
Mason Chisels . . . . .	16
Tooth Chisels. . . . .	16
Electricians Chisels . . . . .	16
Floor Chisels . . . . .	16
Flat Brick Chisels . . . . .	16
Plugging Chisels . . . . .	16
Concrete Chisels . . . . .	16
Wood & Steel Chisels. . . . .	16
Strike Guard Tools . . . . .	17
<b>PUNCHES</b> . . . . .	18
Solid Punches . . . . .	19
Pin Punches . . . . .	19
Long Roll Punches . . . . .	19
Roll Pin Punches . . . . .	19
Alignment Punches . . . . .	19
Center Punches . . . . .	19
Prick Punches . . . . .	19
<b>NAIL SETS</b> . . . . .	20
<b>STAR DRILLS</b> . . . . .	21-22
<b>SCREW EXTRACTORS</b> . . . . .	22
<b>BARS</b> . . . . .	23-25
<b>FARRIER TOOLS</b> . . . . .	26
<b>HITCH PINS</b> . . . . .	27
<b>COMBINATION KITS &amp; ROLLS</b> . . . . .	27-28
<b>COMBINATION DISPLAYS</b> . . . . .	28-30

---

## TERMS & CONDITIONS

- Prepaid freight on \$215 orders within continental United States
- Most orders shipped with 48 hours
- No "broken box" charge
- Payment Terms: 1% - 15 Days. Net 30.
- Unconditional Guarantee (Broken or misused tools should be replaced to your customers at no charge. Hold merchandise for replacement by area representative)
- Returned shipments are subject to a 15% restocking fee and must be accompanied by a "Permission Granted" letter issued by Northbridge Tool, LLC

## SUPERIOR QUALITY SCREWDRIVERS

- **Precision Ground**
- **Professional Quality**

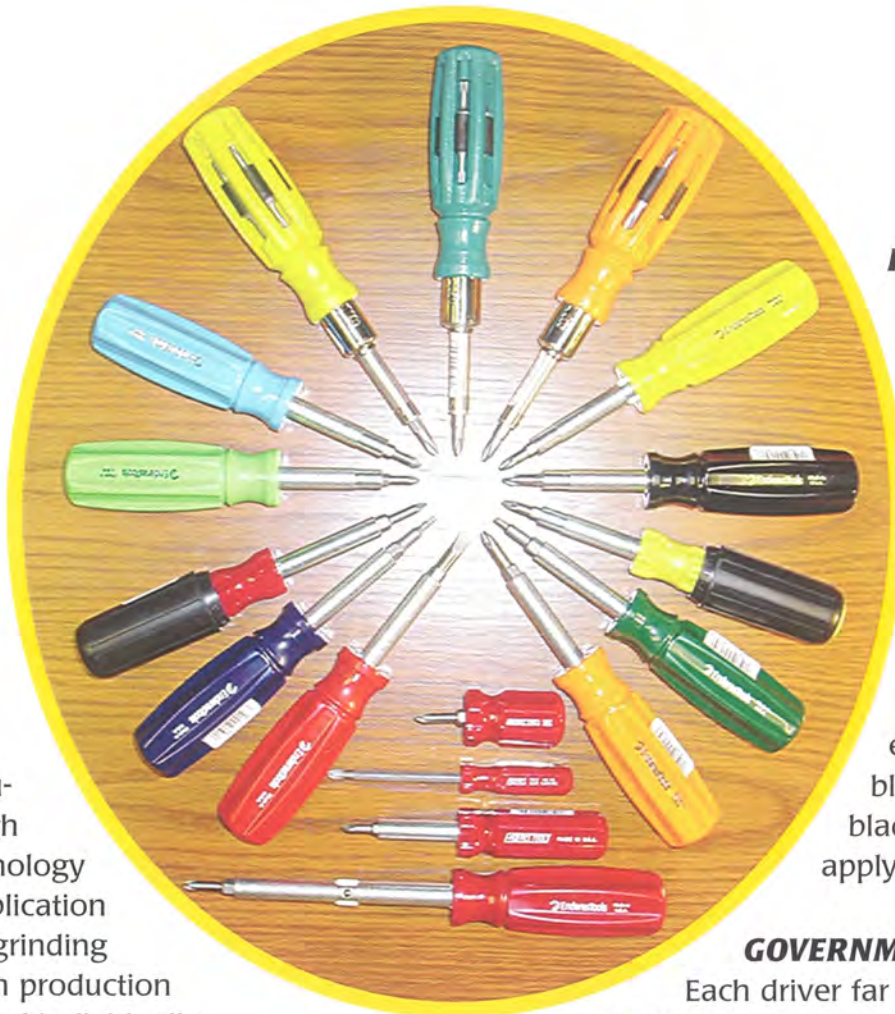

### **MATERIAL**

High carbon, fine grained, open hearth tool steel guarantees high blade quality.

### **PRODUCTION**

All Enderes® bits, both Flat and Phillips types are manufactured through advanced technology and special application high precision grinding machines. Each production step is performed individually; one piece at a time.

### **TIPS**

Slotted bits have tip and flat surfaces precision ground. Phillips bits have a special precision geometry which transmits higher torque, decreases screw or screwdriver slippage and reduces ejection forces for less wear and longer edge life.

### **HANDLES**

Generous size for operator comfort and high-torque. Unbreakable acetate plastic, extrusion and turn processed, first quality grade.

### **BLADES**

Heat treated over entire length. Sand-blast shot over entire blade. Hexagon steel to apply maximum torque.

### **GOVERNMENT SPECS**

Each driver far exceeds all Federal torque test requirements for strength and durability.

### **QUALITY CONTROL**

All Enderes® screwdrivers undergo rigorous in-process and final quality control inspections. This assures Enderes® High Quality Standards.

### **ENDERES® GUARANTEE**

Because of our tight quality control, Enderes® will replace any defective item free of charge, excluding normal wear and tear or improper use. Enderes® stands behind the quality for which we are known.

# OPEN STOCK MULTI-BIT SCREWDRIVERS

The unsurpassed professional quality of our multiple bit screwdrivers makes them the handiest, most versatile, and most reliable tool available today with unlimited applications.



### 15-1 SCREWDRIVER

15 different Screw head configurations accessed by 1 unique Screwdriver, combined with the highest quality ratcheting mechanism in the industry. A "must have" in all tool boxes, R.V.'s, boats and automobiles. (15-1 ratcheting mechanism manufactured in Japan or China.)

Bulk Stk #	Carded Stk #	Description	Stock Size	Overall Length	Weight Bulk/Cd	Std. Pkg.
2302		15-1 Ratcheting Screwdriver	1/4"	7-1/2"	0.40/ *	1
2305	*	5 Pc. Ratcheting Refill	1/4"		2.00/ *	1
2310	*	10 Pc. 15-1 Ratcheting Display			4.55/ *	1
**	2312	1/8" & 5/32" Slotted Bit	1/4"	2"	** /0.05	6
**	2314	3/16" & 1/4" Slotted Bit	1/4"	2"	** /0.05	6
**	2316	#P0 - #P3 Phillips Bit	1/4"	2"	** /0.05	6
**	2318	#P1 - #P2 Phillips Bit	1/4"	2"	** /0.05	6
**	2320	1/4" Slotted & # P2 Phil. Bit	1/4"	2"	** /0.05	6
**	2322	T15 - T20 Torx® Type Bit	1/4"	2"	** /0.05	6
**	2324	#S1 - #S2 Square Bit	1/4"	2"	** /0.05	6

**SPECIFY COLOR WHEN ORDERING**



15-1 RATCHETING DISPLAY STOCK #2310

### 4-1 SCREWDRIVER

Four different screwdriver bits in one gives it unlimited applications.

Bulk Stk #	Carded Stk #	Description	Stock Size	Overall Length	Weight Bulk/Carded	Std. Pkg.
2180	2186	4-1 Screwdriver	5/16"	7-1/2"	0.34/0.36	12
2182	2188	Flat 3/16" & 5/16" Bit	5/16"	3"	0.02/0.05	6
2184	2190	Phillips PB1 & PB2 Bit	5/16"	3"	0.02/0.05	6
2187	2191	Replacement Tube		4-1/2"	0.08/0.11	6



### 4-1 TWIN PACK

4-1 Screwdriver Twin Pack, includes one Regular 4-1 Screwdriver and one Mini 4-1 Screwdriver. Available Private Labeled.

Stk #	Description	Weight	Pkg.
2160	4-1 Twin Pack	0.60	12



### 12 PACK

Stk #	Description	Weight	Pkg.
2204	6x2 12 Pk. Dsply	4.38	1



### 24 PACK

Stk #	Description	Weight	Pkg.
2208	6x4 24 Pk. Dsply	8.66	1



### 24 PACK

Stk #	Description	Weight	Pkg.
2192	6x4 24 Pk. Dsply	8.16	1
Stk. #	Description		
0599	Foam Board Only		



### HI-VISIBILITY ORANGE 4-1 SCREWDRIVER

Four different screwdriver bits in one gives it unlimited applications.



Bulk Stk #	Carded Stk #	Description	Stock Size	Overall Length	Weight Bulk/Cd	Std. Pkg.
2175	*	Hi-Vis Orange 4-1	5/16"	7-1/2"	0.34/ *	12
2182	2188	Flat 3/16" & 5/16" Bit	5/16"	3"	0.02/0.05	6
2184	2190	Phillips PB1 & PB2 Bit	5/16"	3"	0.02/0.05	6
2187	2191	Replacement Tube		4-1/2"	0.08/0.11	6



Stk. #	Description	Weight	Pkg.
2207	12 Pk. Dsply	4.38	1

### CUSHION GRIP 4-1 SCREWDRIVER

The Cushion Grip 4-1 Screwdriver provides added comfort as well as a bigger handle for added torque. The rubber sleeve WILL NOT slip or twist.



Bulk Stk #	Carded Stk #	Description	Stock Size	Overall Length	Weight Bulk/Cd	Std. Pkg.
2154	2156	Cushion Grip 4-1 SD	5/16"	7-1/2"	0.36/0.37	12
2182	2188	Flat 3/16" & 5/16" Bit	5/16"	3"	0.02/0.05	6
2184	2190	Phillips PB1 & PB2 Bit	5/16"	3"	0.02/0.05	6
2187	2191	Replacement Tube		4-1/2"	0.08/0.11	6



Stk. #	Description	Weight	Pkg.
2212	12 Pk. Dsply	4.81	1

### 4-1 TORX® TYPE SCREWDRIVER

The 4-1 Torx® Type Screwdriver is well received by the Automotive and Boating Industries and it offers a wide variety of uses.



Bulk Stk #	Carded Stk #	Description	Stock Size	Overall Length	Weight Bulk/Cd	Std. Pkg.
2146	2147	Torx® Type 4-1	5/16"	7-1/2"	0.34/0.38	12
2142	2148	Torx® Type Bit 15/20	5/16"	3"	0.03/0.05	6
2144	2150	Torx® Type Bit 25/30	5/16"	3"	0.03/0.05	6
2187	2191	Replacement Tube		4-1/2"	0.08/0.11	6



Stk. #	Description	Weight	Pkg.
2211	12 Pk. Dsply	4.21	1

### SQUARE RECESS 4-1 SCREWDRIVER

The Square Recess 4-1 Screwdriver is the perfect tool for use in campers and mobile homes, as well as furniture and deck screws.



Bulk Stk #	Carded Stk #	Description	Stock Size	Overall Length	Weight Bulk/Cd	Std. Pkg.
2161	2162	Square Recess 4-1 SD	5/16"	7-1/2"	0.34/0.36	12
2163	2164	Square Recess Bit #0/#1	5/16"	3"	0.02/0.05	6
2165	2166	Square Recess Bit #2/#3	5/16"	3"	0.02/0.05	6
2187	2191	Replacement Tube		4-1/2"	0.08/0.11	6



Stk. #	Description	Weight	Pkg.
2212	12 Pk. Dsply	4.28	1

# OPEN STOCK MULTI-BIT SCREWDRIVERS

## 4-1 MINI SCREWDRIVER

The perfect tool for recreational vehicles, utility drawers, automobiles and boats. Makes a great gift!



Bulk Stk #	Carded Stk #	Description	Stock Size	Overall Length	Weight Bulk/Cd	Std. Pkg.
2139	2140	4-1 Mini Screwdriver	1/4"	5"	0.21/0.22	12
**	2141	Flat 1/4" & 3/16" Bit	1/4"	2"	** /0.10	6
**	2143	Phillips PB1 & PB2 Bit	1/4"	2"	** /0.10	6
**	2145	Replacement Mini Tube		3-1/2"	** /0.01	6

## MINI 4-1CHIP CLIP DISPLAY

Stk. #	Description
2136	Mini Chip Clip (8 Pack)
Weight	Pkg.
2.02	1

## 12 PACK

Stk. #	Description
2203	12 Pc. Dsply
Weight	Pkg.
2.41	1



## EXTRA LONG 4-1 SCREWDRIVER

Designed for the electrician who has a need for a longer driver to access terminal boxes, electrical boxes, etc.

Bulk Stk #	Carded Stk #	Description	Stock Size	Overall Length	Weight Bulk/Cd	Std. Pkg.
2177	2178	Extra Long 4-1 Screwdriver	5/16"	10"	0.45/0.45	12
2182	2188	Flat 3/16" & 5/16" Bit	5/16"	3"	0.02/0.05	6
2184	2190	Phillips PB1 & PB2 Bit	5/16"	3"	0.02/0.05	6
**	2179	E.L. Replacement Tube		6-3/4"	** /0.20	6

## 4-1 TUBE EXTENSION

Customize the length of your standard Enderes® 4-1 Screwdriver and add as many as you like to reach the desired length.



Carded Stock #	Description	Extension Length	Overall Length	Weight	Std. Pkg.
2193	4-1 Tube Extension	4-1/2"	5-1/4"	0.09	6

## 2-1 STUBBY SCREWDRIVER

The 2-1 Stubby Screwdriver has one single bit containing a Phillips PB1 Tip and a 3/16" Flat Tip. For use in those hard to reach applications where a standard length screwdriver will not fit.



Bulk Stk #	Cd Stk #	Description	Stock Size	Overall Length	Weight Bulk/Cd	Std. Pkg.
2181	2185	2-1 Stubby Screwdriver	5/16"	3-1/4"	0.11/0.12	12
2183	2189	Flat 3/16" & Phil. PB1 Bit	5/16"	3"	0.02/0.05	6

## 12 PACK

Stk. #	Description
2210	12 Pc. Dsply
Weight	Pkg.
1.44	1

## CUSHION GRIP 6-1 SCREWDRIVER

The Cushion Grip results in added comfort and a bigger handle for added torque with the same advantages of our 6-1 Screwdriver.



Bulk Stk #	Carded Stk #	Description	Stock Size	Overall Length	Weight Bulk/Cd	Std. Pkg.
2151	2152	6-1 Cushion Grip SD	5/16"	7-1/2"	0.36/0.37	12
**	2149	6-1 Replacement Bits	5/16"	3"	** /0.05	6
		Flat 3/16", 5/16" & Phillips PB1, PB2				
2131	2132	6-1 Replacement Tube	5/16"	4-1/2"	0.08/0.11	6

## 12 PACK

Stk. #	Description
2215	12 Pc. Dsply
Weight	Pkg.
4.75	1

\* Not available Carded

\*\* Not available Bulk

# 6-1 SCREWDRIVERS

The same quality you've come to expect from our 4-1 Screwdriver with the added benefit of 1/4" and 5/16" Nut Drivers.

## SPECIFY COLOR WHEN ORDERING



Bulk Stk #	Carded Stk #	Description	Stock Size	Overall Length	Weight Bulk/Cd	Std. Pkg.
2130	2135	6-1 Screwdriver	5/16"	7-1/2"	0.34/0.36	12
**	2149	6-1 Replacement Bits	5/16"	3"	** /0.05	6
		Flat 3/16", 5/16" & Phillips PB1, PB2				
2131	2132	6-1 Replacement Tube	5/16"	4-1/2"	0.08/0.11	6

(Specify color when ordering - **PB**-Pacific Blue, **HG**-High Vis Green, **B**-Black, **HY**-High Vis Yellow, **HO**-High Vis Orange)



## 12 PACK

(Specify color when ordering - **PB**-Pacific Blue, **HG**-High Vis Green, **B**-Black, **HY**-High Vis Yellow, **HO**-High Vis Orange)

Stk. #	Description	Weight	Pkg.
2216	12 Pc. Dsply	4.31	1

## 24 PACK

(Specify color when ordering - **PB**-Pacific Blue, **HG**-High Vis Green, **B**-Black, **HY**-High Vis Yellow, **HO**-High Vis Orange)

Stk. #	Description	Weight	Pkg.
2218	24 Pk. Dsply	8.16	1

Stk. #	Description
0599	FoamBoard Only

# REVERSIBLE BIT SCREWDRIVERS

## 2-1 REVERSIBLE BIT SCREWDRIVERS

Enderes® has revolutionized the standard fixed blade screwdriver! A new design, developed and patented by Enderes® Tool Co., puts a Phillips tip on one end and a Flat tip on the other end of one blade. This gives you two full-size, full-strength screwdriver blades in one handle! Available in 7 colors.



Specify color when ordering - **R**-Red, **PB**-Pacific Blue, **HG**-High Vis Green, **HY**-High Vis Yellow, **HO**-High Vis Orange, **BL**-Black, **P**-Purple

Bulk Stk #	Carded Stk #	Description	Stock Size	Overall Length	Weight Bulk/Cd	Std. Pkg.
0911	0913	2-1 Pocket Screwdriver	3/16"	5"	0.06/0.06	6
2170	*	0911 Replacement Bit	3/16"	4-1/2"	0.02/ *	6

## 24 Pack

Stk. #	Description
0917	24 Pc. 2-1 Pocket
Weight	Pkg.
0.64	1



**4-1 POCKET PEN SCREWDRIVER**

4 working tips made of Heat Treated S-2 Steel allows this screwdriver to be used for a variety of applications. The size of a pen fits neatly in your shirt pocket. Each cap contains openings so you can see the bit configurations before removing the cap. Available in 24 Piece Display only.

**Pocket Size Screwdriver- Full size TOUGH!**

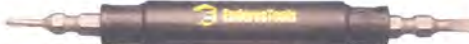

Contains: 2 Slotted tips—1.5mm (1/16") - 3mm (1/8")  
2 Phillips tips—#PO - P00



**24PACK**  
Stk. # Description Wt. Pkg.  
2124 24 Pc. Dsply 1.19 1

**MULTI-BIT SCREWDRIVER MERCHANDISER**

An attractive and compact merchandiser designed to display the highest volume, highest profit products within the Screwdriver market. Each product comes complete with UPC code and product descriptions. 81 total pieces including 3 each of all SKU's. Tool hangers included. Gives your customers an excellent selection.



CD MULTI-BIT SCREWDRIVER MERCHANDISER STOCK #2120

CD MULTI-BIT SCREWDRIVER MERCHANDISER (RACK ONLY) STOCK #8165

Carded Stk #	Description	Stock Size	Overall Length	Weight Bulk/Cd	Std. Pkg.
2186	4-1 Screwdriver	5/16"	7-1/2"	0.36	3
2156	Cushion Grip 4-1 Screwdriver	5/16"	7-1/2"	0.37	3
2135	6-1 Screwdriver	5/16"	7-1/2"	0.36	3
2152	Cushion Grip 6-1 Screwdriver	5/16"	7-1/2"	0.37	3
2147	Torx® Type 4-1 Screwdriver	5/16"	7-1/2"	0.38	3
2162	Square Recess 4-1 Screwdriver	5/16"	7-1/2"	0.36	3
2140	4-1 Mini Screwdriver	1/4"	5"	0.22	3
2178	Extra Long 4-1 Screwdriver	5/16"	10"	0.45	3
2188	Flat 3/16" & 5/16" Bit	5/16"	3"	0.05	3
2190	Phillips PB1 & PB2 Bit	5/16"	3"	0.05	3
2148	Torx® Type Bit 15/20	5/16"	3"	0.05	3
2150	Torx® Type Bit 25/30	5/16"	3"	0.05	3
2164	Square Recess #0 & #1	5/16"	3"	0.05	3
2166	Square Recess #2 & #3	5/16"	3"	0.05	3
2189	Flat 3/16" & PB1 Bit	5/16"	3"	0.05	3
2149	6-1 Replacement Bits- Flat 3/16"-5/16" & Phillips PB1-PB2	5/16"	3"	0.05	3
2141	Flat 1/4" & 3/16" Bit	1/4"	2"	0.10	3
2143	Phillips PB1 & PB2 Bit	1/4"	2"	0.10	3
0913	2-1 Pocket Screwdriver	3/16"	5"	0.06	3
2185	2-1 Stubby Screwdriver	5/16"	3-1/4"	0.12	3
2145	Replacement Mini Tube		3-1/2"	0.01	3
2132	6-1 Replacement Tube		4-1/2"	0.11	3
2191	4-1 Replacement Tube		4-1/2"	0.11	3
2193	4-1 Tube Extension		5-1/4"	0.09	3
2179	Extra Long Tube Replacement		6-3/4"	0.40	3

**DUMP BIN MERCHANDISER**

Pop the top off this End Cap Display and you are ready to sell. This End Cap Display comes fully loaded with 288 6-1 Screwdrivers and is made up with the following color choices: Black, Hi Viz Yellow, Hi Viz Orange, Hi Viz Green, and Pacific Blue. Red handle in 4-1 Screwdriver only.

Stk. #	Description	Quan.	Weight
9001	4-1 Screwdriver	288	110.00
9002	Hi-Vis 4-1 Screwdriver	288	110.00
9003	6-1 Screwdriver	288	110.00
9004	Combo	288	104.00

Combo includes:

4-1 Screwdriver	84
Hi-Vis Screwdriver	48
6-1 Screwdriver	84
Mini 4-1 Screwdriver	48
4-1 Torx® Type	12
4-1 Square Recess	12



DUMP BIN MERCHANDISER STOCK #SEE LEFT

**PRIVATE LABEL SCREWDRIVERS & BARS**

**SCREWDRIVERS**

Enderes® Multi-Bit Screwdrivers are available "Private Labeled". Your name, phone number, message - anything you want - can be printed on each screwdriver! See below for details.



- 2180 - 4-1
- 2161 - Sq. Recess
- 2175 - Hi-Vis 4-1
- 2130 - 6-1
- 2157 - Torx® 4-1
- 2302 - 15-1 Ratchet\*

One or two lines of type in one flute of the handle - 30 Letters/spaces maximum.

**12 PT LETTERS** (ONE LINE)  
**9 PT LETTERS** (TWO LINES)  
\* One Line Imprint Only

- 2139 - Mini 4-1

One or two lines of type in one flute of the handle - 18 Letters/spaces maximum.

**12 PT LETTERS** (ONE LINE)  
**9 PT LETTERS** (TWO LINES)

- 2154 - Cushion Grip 4-1
- 2151 - Cushion Grip 6-1

One line of type in one flute of the handle - 24 Letters/spaces maximum.

**9 PT LETTERS** (ONE LINE)

- 0911 - 2-1 Pocket

One line of type in one flute of the handle - 17 Letters/spaces maximum.

**9 PT LETTERS** (ONE LINE)

**BARS**

Enderes® Bars are available "Private Labeled".



Stock # 0302

Stock # 0298

Stock # 0300

Stock # 3006

ASK YOUR ENDERES® REPRESENTATIVE OR CALL US FOR INFORMATION ON OUR "TAG ON" PROGRAM AND PRIVATE LABEL PROGRAM FOR OUR D16, D16P, D36 & D37 BARS.

## OPEN STOCK SCREWDRIVERS

### FLAT TIPPED SCREWDRIVERS

Oversized handles for operator comfort and maximum torque.



Bulk Stk #	Carded Stk #	Description	Blade Length	Stock Size	Overall Length	Weight Bulk/Carded	Std. Pkg.
0910	0827	Flat Tip 3164	4"	3/16"	7-1/2"	0.16/0.18	6
0912	0832	Flat Tip 3167	7"	3/16"	10-1/2"	0.17/0.21	6
0914	0837	Flat Tip S1415	1-1/2"	1/4"	3-3/8"	0.12/0.13	6
0916	0842	Flat Tip 1404	4"	1/4"	8-1/4"	0.25/0.28	6
0918	0847	Flat Tip 1406	6"	1/4"	10-1/4"	0.28/0.31	6
0920	0852	Flat Tip 5164	4"	5/16"	8-1/4"	0.28/0.31	6
0922	0857	Flat Tip 5167	7"	5/16"	11-1/4"	0.34/0.38	6
0924	0862	Flat Tip 3808	8"	3/8"	12-3/4"	0.51/0.53	6
0926	0867	Flat Tip 3810	10"	3/8"	14-3/4"	0.25/0.60	6

### PHILLIPS TIPPED SCREWDRIVERS

The Phillips Screwdriver has a special precision geometry which increases torque, decreases screwdriver slippage & reduces ejection forces, resulting in less wear & longer tip life.



Bulk Stk #	Carded Stk #	Description	Blade Length	Stock Size	Overall Length	Weight Bulk/Carded	Std. Pkg.
0928	0872	Phillips PB1	3"	3/16"	6-1/2"	0.15/0.18	6
0930	0877	Phillips PB2	4"	1/4"	8-1/2"	0.25/0.28	6
0932	0882	Phillips PB3	6"	5/16"	10-1/4"	0.34/0.38	6
0934	0887	Stubby PB2	1-1/2"	1/4"	3-3/4"	0.11/0.13	6

### EXTRA LONG SCREWDRIVERS

Designed to reach screws in recessed locations.



Carded Stk #	Description	Blade Length	Stock Size	Overall Length	Weight Bulk/Carded	Std. Pkg.
0937	Flat 3/16"	10"	3/16"	13-1/2"	0.23	6
0939	Flat 1/4"	10"	1/4"	14"	0.36	6
0935	Phillips PB1	10"	3/16"	13-1/2"	0.22	6
0936	Phillips PB2	10"	1/4"	14"	0.36	6

### FIXED BLADE POCKET SCREWDRIVERS

Same great manufacturing design as our Standard Fixed Blade screwdrivers but in a compact 5" overall length. Comes complete with pocket clip.



Carded Stk #	Description	Blade Length	Stock Size	Overall Length	Weight Bulk/Carded	Std. Pkg.
0906	Flat 3/16"	3"	3/16"	5"	0.07	6
0908	Phillips PB1	3"	3/16"	5"	0.07	6
0909	Combo Pack of 1 each Flat & Phillips Screwdrivers		3/16"	5"	0.14	6

## SCREWDRIVER KITS

### SCREWDRIVER KIT #4

Four of our tough forged Flat Tips in a re-usable pouch.

S.D.#4 Stock #0942

Bulk Stk #	Description	Blade Length	Stock Size	Overall Length	Weight	Std. Pkg.
0914	Flat Tip S1415	1-1/2"	1/4"	3-3/8"	0.11	1
0916	Flat Tip 1404	4"	1/4"	8-1/4"	0.25	1
0922	Flat Tip 5167	7"	5/16"	11-1/4"	0.34	1
0924	Flat Tip 3808	8"	3/8"	12-3/4"	0.50	1



### SCREWDRIVER KIT #5

Combination kit of the two most popular Phillips Tips and three most popular Flat Tips.

S.D.#5 Stock #0944

Bulk Stk #	Description	Blade Length	Stock Size	Overall Length	Weight	Std. Pkg.
0910	Flat Tip 3164	4"	3/16"	7-1/2"	0.15	1
0916	Flat Tip 1404	4"	1/4"	8-1/4"	0.25	1
0920	Flat Tip 5164	4"	5/16"	8-1/4"	0.28	1
0928	Phillips PB1	3"	3/16"	6-1/2"	0.15	1
0930	Phillips PB2	4"	1/4"	8-1/2"	0.25	1



### SCREWDRIVER KIT #2

Features the two most popular Phillips Tip and Flat Tip screwdrivers in a re-usable pouch.

S.D.#2 Stock #0938

Bulk Stk #	Description	Blade Length	Stock Size	Overall Length	Weight	Std. Pkg.
0930	Phillips PB2	4"	1/4"	8-1/2"	0.25	1
0916	Flat Tip 1404	4"	1/4"	8-1/2"	0.25	1



### SCREWDRIVER KIT #3

Includes the three most common Phillips Tip screwdrivers in a convenient re-usable pouch.

S.D.#3 Stock #0940

Bulk Stk #	Description	Blade Length	Stock Size	Overall Length	Weight	Std. Pkg.
0928	Phillips PB1	3"	3/16"	6-1/2"	0.15	1
0930	Phillips PB2	4"	1/4"	8-1/2"	0.25	1
0932	Phillips PB3	6"	5/16"	10-1/4"	0.34	1



## TACK PULLERS

Drop forged from domestic high carbon, open hearth tool steel. Individual heat-treating assures maximum strength. Allows prying against any surface without marring. Tack, nail, clip, or staple pulling notch in blade. A must for oak and other hard woods. Opens paint cans. Longer length provides additional leverage. Available carded only.



Carded Stk #	Description	Blade Length	Stock Size	Overall Length	Wt.	Std. Pkg.
0980	Tack Puller #1	3-3/4"	1/4"	7-1/4"	0.04	6

## SCREWDRIVER MERCHANDISERS

### #78 COUNTER DISPLAY

This display will show all drivers in the "stand up" position. New concept in displaying ... calls attention to the blade, not the handle. The 13 drivers displayed should cover 80% of your screwdriver requests. 6 of each in the display; 78 total screwdrivers.



#78 COUNTER DISPLAY  
STOCK #0547

#78 COUNTER DISPLAY  
(BOARD ONLY) - STOCK #0581

Bulk Stk #	Description	Blade Length	Stock Size	Overall Length	Wt.	Std. Pkg.
0910	Flat Tip 3164	4"	3/16"	7-1/2"	0.15	6
0912	Flat Tip 3167	7"	3/16"	10-1/2"	0.18	6
0914	Flat Tip S1415	1-1/2"	1/4"	3-3/8"	0.11	6
0916	Flat Tip 1404	4"	1/4"	8-1/4"	0.25	6
0918	Flat Tip 1406	6"	1/4"	10-1/4"	0.28	6
0920	Flat Tip 5164	4"	5/16"	8-1/4"	0.28	6
0922	Flat Tip 5167	7"	5/16"	11-1/4"	0.34	6
0924	Flat Tip 3808	8"	3/8"	12-3/4"	0.50	6
0926	Flat Tip 3810	10"	3/8"	14-3/4"	0.56	6
0928	Phillips PB1	3"	3/16"	6-1/2"	0.15	6
0930	Phillips PB2	4"	1/4"	8-1/2"	0.25	6
0932	Phillips PB3	6"	5/16"	10-1/4"	0.34	6
0934	Stubby PB2	1-1/2"	1/4"	3-3/4"	0.11	6



#78 WALL DISPLAY  
STOCK #0548

#78 WALL DISPLAY  
(RACK ONLY) STOCK #0597

### CARDED SCREWDRIVER MERCHANDISER

Helps "pull" merchandise through the store with increase impulse sales... make stocking easy. Also helps "pull" merchandise through the store with "sales pitch" pointing out features of Enderes Tools®. 24" W x 24-1/4" H. For pegboard mounting; includes tool hangers. Displays carded screwdrivers only. 42 total pieces.



Cd. SCREWDRIVER  
MERCHANDISER  
STOCK #0888

Cd. SCREWDRIVER  
MERCHANDISER  
(RACK ONLY) STOCK #8140

Carded Stk #	Description	Blade Length	Stock Size	Overall Length	Weight Bulk/Carded	Std. Pkg.
0872	Phillips PB1	3"	3/16"	6-1/2"	0.18	3
0877	Phillips PB2	4"	1/4"	8-1/2"	0.28	3
0882	Phillips PB3	6"	5/16"	10-1/4"	0.38	3
0887	Stubby PB2	1-1/2"	1/4"	3-3/4"	0.13	3
0906	Flat 3/16" Pocket	3"	3/16"	5"	0.06	3
0908	Phillips PB1 Pocket	3"	3/16"	5"	0.06	3
0909	Combo Pack of Flat & Phillips Screwdrivers				0.04	3
0827	Flat Tip 3164	4"	3/16"	7-1/2"	0.18	3
0832	Flat Tip 3167	7"	3/16"	10-1/2"	0.21	3
0842	Flat Tip 1404	4"	1/4"	8-1/4"	0.21	3
0837	Flat Tip S1415	1-1/2"	1/4"	3-3/8"	0.13	3
0847	Flat Tip 1406	6"	1/4"	10-1/4"	0.31	3
0852	Flat Tip 5164	4"	5/16"	8-1/4"	0.31	3
0857	Flat Tip 5167	7"	5/16"	11-1/4"	0.38	3

### EXTRA LONG SCREWDRIVER MERCHANDISER

Designed to reach screws in recessed locations. 13" W x 21" H. 12 pieces total.

Cd. EXTRA LONG  
SCREWDRIVER MERCHANDISER  
STOCK #0933

Cd. EXTRA LONG  
SCREWDRIVER MERCHANDISER  
(RACK ONLY) STOCK #8125



Carded Stk #	Description	Blade Length	Stock Size	Overall Length	Weight	Std. Pkg.
0937	Flat 3/16"	10"	3/16"	13-1/2"	0.23	3
0939	Flat 1/4"	10"	1/4"	14"	0.36	3
0935	Phillips PB1	10"	3/16"	13-1/2"	0.22	3
0936	Phillips PB2	10"	1/4"	14"	0.36	3

### #78 WALL DISPLAY

This 12" x 21-1/4" display merchandises the same product mix as our counter display but is made for pegboard mounting.

### #37 WALL DISPLAY

A 9" wide display for pegboard mounting. Displays 6 of our most popular drivers...36 total screwdrivers!



#37 WALL DISPLAY  
STOCK #0550

#37 WALL DISPLAY  
(RACK ONLY)  
STOCK #0598

Bulk Stk #	Description	Blade Length	Stock Size	Overall Length	Weight	Std. Pkg.
0928	Phillips PB1	3"	3/16"	6-1/2"	0.15	6
0930	Phillips PB2	4"	1/4"	8-1/2"	0.25	6
0910	Flat Tip 3164	4"	3/16"	7-1/2"	0.15	6
0916	Flat Tip 1404	4"	1/4"	8-1/4"	0.25	6
0918	Flat Tip 1406	6"	1/4"	10-1/4"	0.28	6
0920	Flat Tip 5164	4"	5/16"	8-1/4"	0.28	6

### OFFSET SCREWDRIVER MERCHANDISER

12 pieces total. 13" W x 11-1/4" H. Offsets are covered by Enderes® famous over-the-counter guarantee.



Cd. OFFSET SCREWDRIVER  
MERCHANDISER  
STOCK #0949

Cd. OFFSET SCREWDRIVER  
MERCHANDISER  
(RACK ONLY) STOCK #8150

Carded Stk #	Description	Size	Stock Size	Overall Length	Weight	Std. Pkg.
0947	#6-#8 Flat		1/4"	4-1/2"	0.12	3
0946	#10-#12 Flat		1/4"	4-1/2"	0.12	3
0945	#8-#10/PB2 Combo		1/4"	4-1/2"	0.12	3
0948	PB1/PB2 Phillips		1/4"	4-1/2"	0.12	3

**F.Y.I.**

... Did you know  
you can order from  
Enderes Catalog  
online:  
[www.Enderes.com](http://www.Enderes.com)



## PROFESSIONAL BULK POWER BITS

- High Carbon, Open Hearth Tool Steel
- Industrial Quality
- Individually Heat-treated











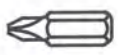
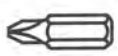
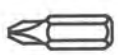

**At last, a tougher, longer lasting Power Bit! Enderes® special precision tip geometry transmits higher torque into the screw, resulting in a decrease in the screwhead slippage, a reduction in the ejection forces, thus giving low wear, and longer tip life. Some available carded or in a variety of pieces counter displays.**

- All bits are manufactured in Taiwan at a high quality ISO 9002 Certified facility. The bits are made to Enderes® exact specifications for bit tolerances and Rockwell hardness.
- The Highest Grade Tool Steel is used to insure Professional Quality and Durability.
- Wide variety of Power Bits, Sockets and Accessories to select from. All competitively priced.
- Build your own display with our space saving Rack. Wall mount or Counter Top.
- Each Bowl is labeled and UPC coded for your convenience.











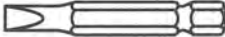
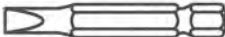

### 1" Power Bits - S-2 Steel

Stk #	Description	Weight	
<b>+</b> #1 Phillips			
5315	250 piece Fishbowl	3.50	
5317	125 piece Refill Bag	1.25	
<b>+</b> #2 Phillips			
5305	250 piece Fishbowl	3.50	
5307	125 piece Refill Bag	1.25	
<b>+</b> #2 Phillips Reduced Head			
5310	250 piece Fishbowl	3.50	
5312	125 piece Refill Bag	1.25	
<b>+</b> #3 Phillips			
5300	250 piece Fishbowl	3.50	
5302	125 piece Refill Bag	1.25	
<b>+</b> T10 Torx®			
5318	150 piece Fishbowl	2.25	
5319	75 piece Refill Bag	.94	
<b>+</b> T15 Torx®			
5320	150 piece Fishbowl	2.25	
5322	75 piece Refill Bag	.94	
<b>+</b> T20 Torx®			
5325	150 piece Fishbowl	2.25	
5327	75 piece Refill Bag	.94	
<b>+</b> T25 Torx®			
5330	150 piece Fishbowl	2.25	
5332	75 piece Refill Bag	.94	
<b>+</b> T30 Torx®			
5333	150 piece Fishbowl	2.25	
5334	75 piece Refill Bag	.94	
<b>+</b> #1 Square Recess			
5335	250 piece Fishbowl	3.50	
5337	125 piece Refill Bag	1.25	
<b>+</b> #2 Square Recess			
5340	250 piece Fishbowl	3.50	
5342	125 piece Refill Bag	1.25	
<b>+</b> #2 Phillips Dry Wall Indenter			
5345	100 piece Fishbowl	2.94	
5347	50 piece Refill Bag	1.41	

# "FIT ALL" POWER BITS









## 2" Power Bits -S-2 Steel/6150

Stk #	Description	Weight	
<b>#6-#8 Flat</b>			
0982	Carded #6-#8-1 per card	0.03	
0983	125 piece Fishbowl	3.88	
<b>#8-#10 Flat</b>			
0984	Carded #8-#10-1 per card	0.03	
0985	125 piece Fishbowl	3.88	
<b>#10-#12 Flat</b>			
0986	Carded #10-#12-1 per card	0.03	
0987	125 piece Fishbowl	3.88	
<b>#1 Phillips</b>			
0988	Carded PB1-1 per card	0.03	
0989	125 piece Fishbowl	3.88	
0952	70 piece Refill Bag	2.10	
<b>#2 Phillips</b>			
0990	Carded PB2-1 per card	0.03	
0991	125 piece Fishbowl	3.88	
0954	70 piece Refill Bag	2.10	
<b>#3 Phillips</b>			
0992	Carded PB3-1 per card	0.03	
0993	125 piece Fishbowl	3.88	
0956	70 piece Refill Bag	2.10	
<b>T10 Torx®</b>			
5415	125 piece Fishbowl	2.63	
5417	75 piece Refill Bag	1.50	
<b>T15 Torx®</b>			
5420	125 piece Fishbowl	2.63	
5422	75 piece Refill Bag	1.50	
<b>T20 Torx®</b>			
5424	125pc Fishbowl	2.69	
5426	75pc Refill Bag	1.55	
<b>T25 Torx®</b>			
5425	125 piece Fishbowl	2.63	
5427	75 piece Refill Bag	1.50	
<b>T30 Torx®</b>			
5430	125 piece Fishbowl	2.63	
5432	75 piece Refill Bag	1.50	
<b>#1 Square Recess</b>			
0970	Carded-1 per card	0.04	
0961	125 piece Fishbowl	3.88	
0962	70 piece Refill Bag	2.10	

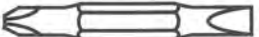
## 2" Square Recess - continued

Stk #	Description	Weight	
<b>#2 Square Recess</b>			
0972	Carded-1 per card	0.04	
0963	125 piece Fishbowl	3.88	
0964	70 piece Refill Bag	2.10	
<b>#3 Square Recess</b>			
0974	Carded-1 per card	0.04	
0965	125 piece Fishbowl	3.88	
0966	70 piece Refill Bag	2.10	

## 2" Power Bits - Double Ended - S-2 Steel

<b>#1 Phillips x 3/16" Flat</b>			
5405	75 piece Fishbowl	2.38	
5407	40 piece Refill Bag	1.20	
<b>#2 Phillips x 1/4" Flat</b>			
5410	75 piece Fishbowl	2.38	
5412	40 piece Refill Bag	1.20	
<b>#2 Phillips x #2 Phillips</b>			
5400	75 piece Fishbowl	2.38	
5402	40 piece Refill Bag	1.20	
<b>6 Pack - Flat &amp; Phillips</b>			
0994	1 ea.-#6/#8 flat, #8/#10 flat, #10/#12 flat, PB1, PB2, PB3,	.16	
<b>10 Pack - #2 Phillips</b>			
0996	PB2 Phillips	.41	
<b>6 Pc. Combo Pack</b>			
0976	1 ea.-#8/#10 flat, #10/#12 flat, PB2, PB3, #2 Sq Rec, #3 Sq Rec	.16	









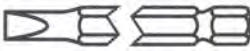

## 2-3/4" Power Bits - S-2 Steel

<b>#2 Phillips</b>			
5308	50 piece Fishbowl	1.83	
5309	25 piece Refill Bag	.85	
<b>3-1/2" Power Bits - S-2 Steel</b>			
<b>#2 Phillips</b>			
5313	50 piece Fishbowl	2.33	
5314	25 piece Refill Bag	1.10	

# "FIT ALL" POWER BITS





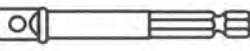

## 6" XL Power Bits - S-2 Steel

Stk #	Description	Weight	
<b>XL #6-#8 Flat</b>			
Not available bulk			
0967	XL Carded-1 per card	0.10	
<b>XL #8-#10 Flat</b>			
Not available bulk			
0969	XL Carded-1 per card	0.10	
<b>XL #10-#12 Flat</b>			
Not available bulk			
0971	XL Carded-1 per card	0.10	
<b>XL #1 Phillips</b>			
0973	XL Carded-1 per card	0.10	
0950	25 piece Fishbowl*	2.51	
0951	15 piece Refill Bag	1.35	
<b>XL #2 Phillips</b>			
0975	XL Carded-1 per card	0.10	
0953	25 piece Fishbowl*	2.51	
0955	15 piece Refill Bag	1.35	
<b>XL #3 Phillips</b>			
Not available bulk			
0977	XL Carded-1 per card	.010	
<b>XL 6 Pc. Combo (1 of each)</b>			
Not available bulk			
0979	XL-1 ea. #6/#8 flat, #8/#10 flat, #10/#12 flat, PB1, PB2, PB3	.054	
<b>XL T10 Torx®</b>			
5435	25 piece Fishbowl*	1.13	
5437	15 piece Refill Bag	.60	
<b>XL T15 Torx®</b>			
5440	25 piece Fishbowl*	1.13	
5442	15 piece Refill Bag	.60	
<b>XL T25 Torx®</b>			
5445	25 piece Fishbowl*	1.38	
5447	15 piece Refill Bag	.75	









## 3" Socket Drives - 6150 Steel

Stk #	Description	Weight	
<b>3" x 1/4" Socket Drive</b>			
5475	50 piece Fishbowl	2.63	
5477	25 piece Refill Bag	1.25	
<b>3" x 3/8" Socket Drive</b>			
5480	50 piece Fishbowl	4.13	
5482	25 piece Refill Bag	2.00	

## Magnetic Bit Holders - 6150 Steel

Stk#	Description	Weight	
<b>1/4" x 3" Magnetic Bit Holder</b>			
5450	50 pc fishbowl	2.63	
5452	25 pc refill bag	1.25	
<b>1/4" x 3" Magnetic Bit Holder</b>			
5460	25pc fishbowl	1.66	
5462	15pc refill bag	.93	
<b>1/4" x 4-3/4" Magnetic Bit Holder</b>			
5465	25pc fishbowl	2.50	
5467	15pc refill bag	1.44	
<b>Magnetic Bit Holder wLock</b>			
5455	25pc fishbowl	1.88	
5457	15pc refill bag	1.05	

## Magnetic Nut Setters - 6150 Steel

Stk#	Description	Weight	
<b>1-3/4" x 1/4" Magnetic Nut Setter</b>			
5465	50pc fishbowl	2.13	
5467	25pc refill bag	1.00	
<b>1-3/4" x 5/16" Magnetic Nut Setter</b>			
5505	50pc fishbowl	2.63	
5507	25pc refill bag	1.25	
<b>1-3/4" x 3/8" Magnetic Nut Setter</b>			
5510	50pc fishbowl	2.63	
5512	25pc refill bag	1.25	
<b>1-3/4" x 7/16" Magnetic Nut Setter</b>			
5515	50pc fishbowl	3.13	
5517	25pc refill bag	1.50	
<b>2-1/2" x 1/4" Magnetic Nut Setter</b>			
5550	25pc fishbowl	1.63	
5562	15pc refill bag	.90	
<b>2-1/2" x 5/16" Magnetic Nut Setter</b>			
5555	25pc fishbowl	1.83	
5557	15pc refill bag	1.05	
<b>2-1/2" x 3/8" Magnetic Nut Setter</b>			
5560	25pc fishbowl	2.13	
5562	15pc refill bag	1.20	
<b>2-1/2" x 7/16" Magnetic Nut Setter</b>			
5565	25pc fishbowl	2.63	
5567	15pc refill bag	1.50	

\*Available in Large Fishbowl only.

## BIN RACK DISPLAYS.



**Six Bin Rack Display (Empty)**

6 Small bowls.

Stk #	Description	Weight
5600	1-6 Small Bowl Bin Rack	1.30

Rack shipped FREE with order of 6 or more Bowls

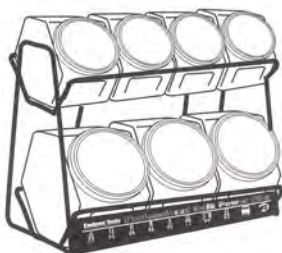

**Seven Bin Combo Rack Display (Empty)**

4 Small bowls, 3 Large bowls.

Stk #	Description	Weight
5601	1-7 Bin Combo Rack	2.31

Rack shipped FREE with order of 7 or more Bowls

**Any of the following items can be ordered in a large Fishbowl.**

**Large Fishbowls can be ordered separately or with rack of 3 large Fishbowls and 4 small Fishbowls**

### 2-1 Pocket Screwdriver

Stk #	Description	Weight
0915	50 piece Fishbowl*	3.37
0957	25 piece Refill Bag	1.50



### 4-1 Mini Screwdriver

Stk #	Description	Weight
2110	15 piece Fishbowl*	3.52
2112	10 piece Refill Bag	2.10



### 2-1 Stubby Screwdriver

Stk #	Description	Weight
2114	24 piece Fishbowl*	3.02
2116	12 piece Refill Bag	1.65



### D-37 Micro Bar

Stk #	Description	Weight
0919	30 piece Fishbowl*	2.38
0959	15 piece Refill Bag	1.13



### NS1 Nail Set 1/32

Stk #	Description	Weight
0770	25 piece Fishbowl*	2.68
0772	15 piece Refill Bag	1.45



### NS2 Nail Set 2/32

Stk #	Description	Weight
0774	25 piece Fishbowl*	2.68
0776	15 piece Refill Bag	1.45



\*Available in Large Fishbowl only.

## "FIT ALL" MERCHANDISERS

### 2" "FIT ALL" MERCHANDISER

Precision ground tips for accurate fit & longer edge life. 19-1/2" W x 9" H. 54 total pieces, 6 of each SKU.

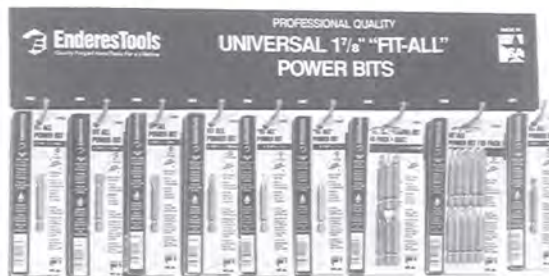

Cd. 2" "FIT ALL" MERCHANDISER STOCK #0998

Cd. 2" "FIT ALL" MERCHANDISER (RACK ONLY) STOCK #8135

Carded Stk #	Description	Cut/Pt.	Overall Length	Wt.	Std. Pkg.
0982	#6-#8 Flat Bit		1-7/8"	0.04	6
0984	#8-#10 Flat Bit		1-7/8"	0.04	6
0986	#10-#12 Flat Bit		1-7/8"	0.04	6
0988	Phillips PB1 Bit		1-7/8"	0.04	6
0990	Phillips PB2 Bit		1-7/8"	0.04	6
0992	Phillips PB3 Bit		1-7/8"	0.04	6
0994	6 pack (1 of ea.)		1-7/8"	0.25	6
0996	No. 2 Phillips/10 pk.		1-7/8"	0.41	6
0972	#2 Square Recess Bit		1-7/8"	0.04	6

### 6" "FIT ALL" MERCHANDISER

Excellent for those hard to reach applications. Additional length allows for faster and easier project completion. 15" W x 11-1/2" H. Compact merchandiser holds 42 total pieces, 6 of each SKU.



Cd. 6" "FIT ALL" MERCHANDISER STOCK #0995

Cd. 6" "FIT ALL" MERCHANDISER (RACK ONLY) STOCK #8130

Carded Stk #	Description	Cut/Pt.	Overall Length	Wt.	Std. Pkg.
0967	XL #6-#8 Flat Bit		6"	0.11	6
0969	XL #8-#10 Flat Bit		6"	0.11	6
0971	XL #10-#12 Flat Bit		6"	0.11	6
0973	XL Phillips PB1 Bit		6"	0.11	6
0975	XL Phillips PB2 Bit		6"	0.11	6
0977	XL Phillips PB3 Bit		6"	0.11	6
0979	XL 6 pack (1 of ea.)		6"	0.68	6

**WE SELL TO SELL AGAIN!**

**That is why you are guaranteed to be stocking the finest Struck Hand Tools available on the market today. Rest assured that your customers are buying the best Struck Hand Tools money can buy.**

## SUPERIOR QUALITY COLD CHISELS

- **Finest Grade Tool Steel**
- **Deep Tempered – Exclusive with Enderes®!**

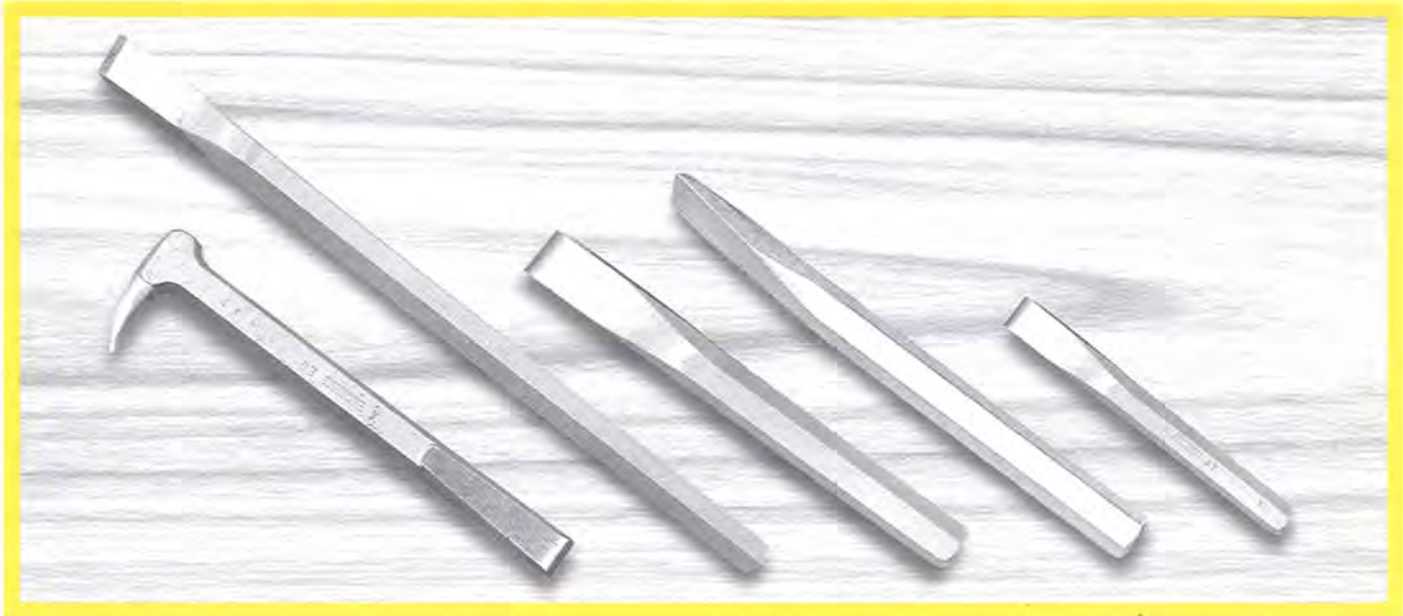

### USE

Cold Chisels are used for cutting, shaping, or removing cold metals softer than the chisel itself such as cast or wrought iron, unhardened steel, aluminum, brass, or copper. Never use a Cold Chisel on concrete, stone, or a metal harder than the chisel's cutting edge.

The chisel has a cutting edge at one end, and a struck face at the other to be struck with a ball-peen or machinists hammer. Never strike with a nail hammer and never strike anywhere except the struck face.

Always strike the chisel with a light, cautious blow when starting a job to determine the relative hardness of the metal to be cut. Always wear safety goggles when using a cold chisel as well as when using all struck hand tools.

### SELECTION

Flat Chisels are the most frequently used Cold Chisels. Enderes Tools® offers them in 17 sizes from 1/4" cut to 1" cut including 12" and 18" extra length models.

### SPECIFICATION

Enderes Tools® Cold Chisels are forged and heat treated using only the finest domestic high carbon tool steel. They conform to all applicable ANSI and ASTM steel standards for materials, physical properties, and testing, including A29-79, A322-79a, A331-74 (1979), A576-79, and A681-76. Rockwell hardness range is C57-59 so your Enderes® Cold Chisel will hold its cutting edge longer and resist excessive wear.

### MAINTENANCE

A dull cutting edge may be sharpened using a common file as described in our "Maintenance" section below.

1. Always wear safety goggles when sharpening a cutting edge and when ever using a striking tool.
2. Rigidly support the tool being sharpened. Secure in a bench vise if possible.
3. Never use grinding to sharpen. This causes excessive heat and may result in a loss of strength, durability and temper.
4. Instead, use a file or stone of medium or fine grit and file away from the cutting edge. This directs heat away from the edge.
5. The original contour of the cutting edge or point should be restored. Flat cold chisels should be restored to a bevel angle of 70 degrees.

Discard any Cold Chisel if it is bent or shows dents, cracks, chips, mushrooming, or excessive wear.

## OPEN STOCK COLD CHISELS

### STANDARD LENGTH COLD CHISELS

All of our Cold Chisels are forged from the finest domestic high carbon tool steel available. Used for cutting and removing metal softer than the cutting edge itself. Individually heat treated to allow for re-sharpening with a file.



Bulk Stk #	Carded Stk #	Description	Cut/Pt.	Stock Size	Overall Length	Weight Bulk/Carded	Std. Pkg.
0001	0600	A-1	1/4"	3/16"	4"	0.03/0.05	6
0004	0603	A-2	5/16"	1/4"	4-1/2"	0.06/0.08	6
0007	0606	A-3	3/8"	5/16"	5"	0.11/0.13	6
0010	0609	A-4	7/16"	3/8"	5-1/2"	0.17/0.17	6
0013	0612	A-5	1/2"	7/16"	5-3/4"	0.25/0.27	6
0016	0615	A-6	5/8"	1/2"	6"	0.36/0.37	6
0019	0618	A-7	3/4"	5/8"	7"	0.62/0.65	6
0022	0621	A-8	7/8"	3/4"	7-1/2"	0.91/0.93	6
0025	0622	A-9	1"	7/8"	9"	1.52/1.55	6

### EXTRA LONG COLD CHISELS

Excellent for cutting & shaping where extra length is needed.



Bulk Stk #	Carded Stk #	Description	Cut/Pt.	Stock Size	Overall Length	Weight Bulk/Carded	Std. Pkg.
0014	*	A-14	1/2"	7/16"	12"	0.55/ *	6
0028	0624	A-10	5/8"	1/2"	12"	0.71/0.71	6
0031	0625	A-11	3/4"	5/8"	12"	1.11/1.11	6
0032	*	A-16	3/4"	5/8"	18"	1.66/ *	6
0033	*	A-17	7/8"	3/4"	12"	1.53/ *	6
0034	*	A-12	7/8"	3/4"	18"	2.30/ *	6
0037	0627	A-13	1"	7/8"	12"	2.07/2.07	6
0039	*	A-18	1"	7/8"	18"	3.20/ *	6

### DROP FORGED STAPLE-PULLER

Used for fence repairs, removing cotter pins, as a staple puller, small hammer, cold chisel, pry-bar, box opener, wedge, etc. Drop forged from one piece of high carbon steel.



Bulk Stk #	Description	Cut/Pt.	Stock Size	Overall Length	Wt.	Std. Pkg.
0143	E-5	5/8"	5/8"	7-1/2"	0.47	6

### RIVET BUSTER

Designed to allow a flush cut with a flat surface.



Bulk Stk #	Carded Stk #	Description	Cut/Pt.	Stock Size	Overall Length	Weight Bulk/Carded	Std. Pkg.
0068	0730	B-9	7/8"	3/4"	9"	0.73/1.13	6

## #436 COLD CHISEL COUNTER DISPLAY

Compact 6" W x 12" D counter or shelf display. Displays 37 total Cold Chisels. 3 each of the fastest moving items, 2 each of the larger sizes.



Stk #	Description	Cut/Pt.	Stock Size	Overall Length	Wt.	Std. Pkg.
0001	A-1	1/4"	3/16"	4"	0.03	3
0004	A-2	5/16"	1/4"	4-1/2"	0.06	3
0007	A-3	3/8"	5/16"	5"	0.11	3
0010	A-4	7/16"	3/8"	5-1/2"	0.17	3
0013	A-5	1/2"	7/16"	5-3/4"	0.25	3
0016	A-6	5/8"	1/2"	6"	0.37	3
0019	A-7	3/4"	5/8"	7"	0.62	3
0022	A-8	7/8"	3/4"	7-1/2"	0.90	3
0025	A-9	1"	7/8"	9"	1.52	2
0028	A-10	5/8"	1/2"	12"	0.71	2
0031	A-11	3/4"	5/8"	12"	1.11	2
0033	A-17	7/8"	3/4"	12"	1.53	2
0037	A-13	1"	7/8"	12"	2.07	2
0014	A-14	1/2"	7/16"	12"	0.55	2

#436 COLD CHISEL COUNTER DISPLAY STOCK #0560

#436 COLD CHISEL COUNTER DISPLAY (BOARD ONLY) STOCK #0557

## CHISEL KITS AND ROLLS

### CHISEL SET NO. 2

3 piece, 5/16" to 1/2" cut for the "hobbyist".

CHISEL SET #2 STOCK #0504



Bulk Stk #	Description	Cut/Pt.	Stock Size	Overall Length	Wt.	Std. Pkg.
0004	A-2	5/16"	1/4"	4-1/2"	0.06	1
0010	A-4	7/16"	3/8"	5-1/2"	0.17	1
0013	A-5	1/2"	7/16"	5-3/4"	0.25	1

### 5 PC. CHISEL ROLL

Five of our most popular cold chisels for the serious DIY'r or beginning Journeyman. Set is conveniently packed in a heavy duty vinyl tool roll.



5 PC. CHISEL ROLL STOCK #0529

Bulk Stk #	Description	Cut/Pt.	Stock Size	Overall Length	Wt.	Std. Pkg.
0007	A-3	3/8"	5/16"	5"	0.11	1
0013	A-5	1/2"	7/16"	5-3/4"	0.25	1
0016	A-6	5/8"	1/2"	6"	0.37	1
0019	A-7	3/4"	5/8"	7"	0.62	1
0022	A-8	7/8"	3/4"	7-1/2"	0.90	1

### 7 PC. CHISEL ROLL

A mid-sized chisel roll for the person who needs a broader selection. This set includes 7 sizes ranging from 5/16" - 7/8" cut. Packed in a heavy duty re-usable vinyl tool roll.



7 PC. CHISEL ROLL STOCK #0523

Bulk Stk #	Description	Cut/Pt.	Stock Size	Overall Length	Wt.	Std. Pkg.
0004	A-2	5/16"	1/4"	4-1/2"	0.06	1
0007	A-3	3/8"	5/16"	5"	0.11	1
0010	A-4	7/16"	3/8"	5-1/2"	0.17	1
0013	A-5	1/2"	7/16"	5-3/4"	0.25	1
0016	A-6	5/8"	1/2"	6"	0.37	1
0019	A-7	3/4"	5/8"	7"	0.62	1
0022	A-8	7/8"	3/4"	7-1/2"	0.90	1

### 9 PC. CHISEL ROLL

This set includes a complete range of standard length cold chisels with cutting edges from 1/4" - 1". Packaged in a heavy duty re-usable vinyl pouch, this set is for the professional user. Easily fits into all professional tool cabinets.



9 PC. CHISEL ROLL STOCK #0531

Bulk Stk #	Description	Cut/Pt.	Stock Size	Overall Length	Wt.	Std. Pkg.
0001	A-1	1/4"	3/16"	4"	0.03	1
0004	A-2	5/16"	1/4"	4-1/2"	0.06	1
0007	A-3	3/8"	5/16"	5"	0.11	1
0013	A-5	1/2"	7/16"	5-3/4"	0.25	1
0016	A-6	5/8"	1/2"	6"	0.37	1
0019	A-7	3/4"	5/8"	7"	0.62	1
0022	A-8	7/8"	3/4"	7-1/2"	0.90	1
0025	A-9	1"	7/8"	9"	1.52	1
0068	B-9	7/8"	3/4"	9"	1.12	1

## COLD CHISEL MERCHANDISER

A complete range of standard cold chisels displayed on our attractive new merchandiser. 19-1/2" W x 15-1/4" H. 24 total pieces, 3 each of the 8 most popular sizes.



Carded Stk #	Description	Cut/Pt.	Stock Size	Overall Length	Wt.	Std. Pkg.
0600	A-1	1/4"	3/16"	4"	0.05	3
0603	A-2	5/16"	1/4"	4-1/2"	0.08	3
0606	A-3	3/8"	5/16"	5"	0.13	3
0612	A-5	1/2"	7/16"	5-3/4"	0.27	3
0615	A-6	5/8"	1/2"	6"	0.36	3
0618	A-7	3/4"	5/8"	7"	0.65	3
0621	A-8	7/8"	3/4"	7-1/2"	0.93	3
0622	A-9	1"	7/8"	9"	1.55	3

Cd. COLD CHISEL MERCHANDISER STOCK #0892

Cd. COLD CHISEL MERCHANDISER (RACK ONLY) STOCK #8100

## SUPERIOR QUALITY STONE & WOOD CHISELS

- **Finest Grade Tool Steel**
- **Deep Tempered – Exclusive with Enderes®!**



### USE

A variety of Chisels are designed for use on stone, concrete, and brick.

Mason Chisels and Brick Sets are used for scoring and cutting block and brick. Tooth Chisels are used to cut soft stone and brick, such as Bedford limestone. Bull Point Concrete Chisels are used for breaking up and drilling concrete.

All-Steel Wood Chisels, including Floor Chisels and Electrician's Chisels are for rough cutting and trimming of both hard and soft woods. They will also cut soft nails and wiring encountered while cutting these soft woods.

Strike Stone and Wood Chisels only with a ball pein or machinist's hammer. Never strike with a nail hammer, and always wear safety goggles when using struck hand tools.

### SELECTION

Brick Sets are available in 3", 3-1/2", and 4" cuts. Mason and Tooth Chisels are available in 2", 2-1/4", and 2-1/2" cuts. Concrete Chisels are available in 12" and 18" lengths. Plugging Chisels are available in 1/8" and 1/4" thicknesses.

### SPECIFICATION

Enderes Tools® Stone and Wood Chisels are forged and heat treated using only the finest domestic high carbon tool steel. They conform to all applicable ANSI and ASTM steel standards for materials, physical properties and tests, including A29-79, A322-80, A331-79, A576-79, and A681-76. All styles fall within the appropriate Rockwell hardness ranges recommended by ANSI and ASTM for their intended application.

### MAINTENANCE

A dull cutting edge may be sharpened using a common file as described in our "Maintenance" section below:

1. Always wear safety goggles when sharpening a cutting edge and when ever using a striking tool.
2. Rigidly support the tool being sharpened. Secure in a bench vise if possible.
3. Never use grinding to sharpen. This causes excessive heat and may result in a loss of strength, durability and temper.
4. Instead, use a file or stone of medium or fine grit and file away from the cutting edge. This directs heat away from the edge.
5. The original contour of the cutting edge or point should be restored. Brick Sets should be restored to a bevel of 45 degrees and Brick Chisels should be restored to a bevel of 90 degrees.

## BRICK SETS

Designed for cutting, trimming, and scoring blocks and bricks. Forged from the finest high carbon tool steel and individually heat-treated for the highest quality. Can be resharpened with a common file.



Bulk Stk #	Carded Stk #	Description	Cut/Pt.	Stock Size	Overall Length	Weight Bulk/Carded	Std. Pkg.
0340	0380	B-14	3"	7/8"	7"	1.26/1.29	6
0341	0382	B-20	3-1/2"	7/8"	7"	1.31/1.33	6
0342	0383	B-26	4"	7/8"	7"	1.31/1.34	6

## CHISELS

### MASON CHISELS

Designed for cutting brick, cement block, cinder block and trimming off excess mortar. Excellent for raking out joints. This powerful thin blade produces very clean cuts.



Bulk Stk #	Carded Stk #	Description	Cut/Pt.	Stock Size	Overall Length	Weight Bulk/Carded	Std. Pkg.
0339	0385	B-115	2"	3/4"	7-1/2"	0.88/0.92	6
0343	0351	B-15	2-1/4"	3/4"	7-1/2"	0.92/0.96	6
0344	0386	B-21	2-1/2"	3/4"	7-1/2"	0.92/0.95	6

### TOOTH CHISELS

Designed to cut and score soft stone such as Bedford, etc. Not to be used on hard stone or cement. Accurate, clean cuts assured from the strong sharp teeth. Also known as a bushing tool for trimming off brick, concrete, or stone.



Bulk Stk #	Carded Stk #	Description	Cut/Pt.	Stock Size	Overall Length	Weight Bulk/Carded	Std. Pkg.
0338	0388	B-116	2"	3/4"	7-1/2"	0.92/0.96	6
0346	*	B-16	2-1/4"	3/4"	7-1/2"	0.93/ *	6
0347	0345	B-22	2-1/2"	3/4"	7-1/2"	0.90/0.93	6

### ELECTRICIAN'S CHISEL

Designed for rough cutting and trimming of hard or soft woods. Short handle accommodates tight working conditions. Used for "roughing-in" electrical outlets, etc.



Bulk Stk #	Carded Stk #	Description	Cut/Pt.	Stock Size	Overall Length	Weight Bulk/Carded	Std. Pkg.
0349	0348	B-17	2-3/4"	3/4"	8-1/2"	1.01/1.03	6

### FLOOR CHISEL

Powerful, thin cutting blade for rough cutting and trimming, removing of tongue and groove flooring, etc. Forged from the finest tool steel and individually heat treated. May be resharpened with a file.



Bulk Stk #	Carded Stk #	Description	Cut/Pt.	Stock Size	Overall Length	Weight Bulk/Carded	Std. Pkg.
0352	0350	B-18	2-3/4"	3/4"	12"	1.43/1.47	6

### FLAT BRICK CHISEL

Also commonly referred to as a "Flat Utility Chisel", this tool is forged from 3/8" x 7/8" rectangular stock steel. When combined with its 1-1/8" cutting edge, the long length enables this chisel to perform where traditional styles cannot. Available in 12", 18".



Bulk Stk #	Carded Stk #	Description	Cut/Pt.	Stock Size	Overall Length	Weight Bulk/Carded	Std. Pkg.
0281	0282	B-27	1-1/8"	7/8"	12"	1.02/1.07	6

### PLUGGING CHISEL

Designed to be used in "tuck-pointing". Removes old cement and mortar from between brick, block, etc.



Bulk Stk #	Carded Stk #	Description	Cut/Pt.	Stock Size	Overall Length	Weight Bulk/Carded	Std. Pkg.
0279	*	D-11A	1/8"	1/2"	10"	0.50	6
0280	*	D-11	1/4"	1/2"	10"	0.56	6

### CONCRETE CHISEL

Also known as a "Bull Point" chisel. Designed for breaking up concrete floors, sidewalks, etc. where it may be impractical to use an air hammer.



Bulk Stk #	Carded Stk #	Description	Cut/Pt.	Stock Size	Overall Length	Wt.	Std. Pkg.
0272	*	B-12A	3/8"	7/8"	12"	2.02	6

### WOOD AND STEEL CHISEL

Designed for rough work in wood; will also cut steel. If you are cutting wood and hit a nail, no problem. Also used for muffler and tailpipe removal.



Bulk Stk #	Carded Stk #	Description	Cut/Pt.	Stock Size	Overall Length	Weight Bulk/Carded	Std. Pkg.
0146	*	E-6	1/2"	3/8"	8"	0.23	6
0149	0729	E-7	3/4"	7/16"	9"	0.38/43	6
0152	*	E-8	1"	1/2"	10"	0.55	6
0155	*	E-9	1-1/4"	5/8"	11"	0.97	6

## MASON TOOLS DISPLAYS

### #20 MASON TOOL COUNTER DISPLAY

Compact 8" W x 12" D counter or shelf display. Excellent way to merchandise and sell large tools in a small area. 20 total pieces, 2 each of 10 different mason tools.



#20 MASON TOOL COUNTER DISPLAY STOCK #0583

#20 MASON TOOL COUNTER DISPLAY (BOARD ONLY) STOCK #0582

### #48 MASON TOOL COUNTER DISPLAY

A larger version counter or shelf display for Mason Tools. An excellent display for keeping your entire inventory. A must for the store that sells Mason Tools in volume. 12" W x 15" D and holds 48 total tools. Displays 13 different tools.



#48 MASON TOOL COUNTER DISPLAY STOCK #0584

#48 MASON TOOL COUNTER DISPLAY (BOARD ONLY) STOCK #0585

Bulk Stk #	Description	Cut/Pt.	Stock Size	Overall Length	Wt.	Std. Pkg.
0340	B-14	3"	7/8"	7"	1.26	6
0341	B-20	3-1/2"	7/8"	7"	1.30	6
0342	B-26	4"	7/8"	7"	1.31	6
0343	B-15	2-1/4"	3/4"	7-1/2"	0.91	4
0344	B-21	2-1/2"	3/4"	7-1/2"	0.92	4
0346	B-16	2-1/4"	3/4"	7-1/2"	0.93	2
0347	B-22	2-1/2"	3/4"	7-1/2"	0.96	2
0338	B-116	2"	3/4"	7-1/2"	0.92	2
0280	D-11	1/4"	1/2"	10"	0.56	3
0279	D-11A	1/8"	1/2"	10"	0.50	3
0349	B-17	2-3/4"	3/4"	8-1/2"	1.01	3
0352	B-18	2-3/4"	3/4"	12"	1.43	3

## MASON TOOL MERCHANDISER

30 piece merchandiser for pegboard or wall mounting. Includes tool hangers. 24" W x 23-1/2" H. Displays 10 different carded Masonry Tools, 3 of each.



Cd. MASON TOOL MERCHANDISER STOCK #0586

Cd. MASON TOOL MERCHANDISER (RACK ONLY) STOCK #8105

Bulk Stk #	Description	Cut/Pt.	Stock Size	Overall Length	Wt.	Std. Pkg.
0380	B-14	3"	7/8"	7"	1.29	3
0382	B-20	3-1/2"	7/8"	7"	1.33	3
0383	B-26	4"	7/8"	7"	1.34	3
0385	B-115	2"	3/4"	7-1/2"	0.92	3
0386	B-21	2-1/2"	3/4"	7-1/2"	0.95	3
0388	B-116	2"	3/4"	7-1/2"	0.96	3
0345	B-22	2-1/2"	3/4"	7-1/2"	0.91	3
0348	B-17	2-3/4"	3/4"	8-1/2"	1.03	3
0350	B-18	2-3/4"	3/4"	12"	1.47	3
0282	B-27	1-1/8"	7/8"	12"	1.07	3



## STRIKE-GUARD TOOLS

- Provide Additional Grip Support
- Extra Hand Protection

### STRIKE-GUARD CHISELS



Bulk Stk #	Description	Cut/Pt.	Stock Size	Overall Length	Wt.	Std. Pkg.
0620	A-7	3/4"	5/8"	7"	0.82	6
0623	A-8	7/8"	3/4"	7-1/2"	1.10	6
0626	A-9	1"	7/8"	9"	1.73	6
0629	A-11	3/4"	5/8"	12"	1.31	6
0632	A-16	3/4"	5/8"	18"	1.86	6
0635	A-17	7/8"	3/4"	12"	1.73	6
0638	A-12	7/8"	3/4"	18"	2.50	6
0641	A-13	1"	7/8"	12"	2.27	6
0644	A-18	1"	7/8"	18"	3.40	6

### STRIKE-GUARD MASON TOOLS



Bulk Stk #	Description	Cut/Pt.	Stock Size	Overall Length	Wt.	Std. Pkg.
0309	B-14	3"	7/8"	7"	1.46	6
0310	B-20	3-1/2"	7/8"	7"	1.50	6
0311	B-26	4"	7/8"	7"	1.51	6
0312	B-115	2"	3/4"	7-1/2"	1.08	6
0313	B-15	2-1/4"	3/4"	7-1/2"	1.11	6
0314	B-21	2-1/2"	3/4"	7-1/2"	1.12	6
0320	B-116	2"	3/4"	7-1/2"	1.12	6
0321	B-16	2-1/4"	3/4"	7-1/2"	1.13	6
0322	B-22	2-1/2"	3/4"	7-1/2"	1.16	6
0323	B-17	2-3/4"	3/4"	8-1/2"	1.21	6
0324	B-18	2-3/4"	3/4"	12"	1.63	6
0307	B-12A	3/8"	7/8"	12"	2.03	6
0308	D-11	1/4"	1/2"	10"	0.60	6
0286	B-27	1-1/8"	7/8"	12"	1.03	6

### STRIKE-GUARD STAR DRILLS



Bulk Stk #	Description	Cut/Pt.	Stock Size	Overall Length	Wt.	Std. Pkg.
0781	F-11	3/4"	5/8"	12"	1.22	6
0787	F-14	1"	3/4"	12"	1.67	6

## STRIKE-GUARD MERCHANDISER

A new and compact way to merchandise 6 of the most commonly used Strike-Guard Tools. Includes 6 Mason Tools. 24" W x 15" H this display includes 2 each of all tools. 12 total. Includes tool hangers.



Bulk Stk #	Description	Cut/Pt.	Stock Size	Overall Length	Wt.	Std. Pkg.	STRIKE-GUARD MERCHANDISER STOCK #0589
0311	B-26	4"	7/8"	7"	1.51	2	
0314	B-21	2-1/2"	3/4"	7-1/2"	1.12	2	
0321	B-16	2-1/4"	3/4"	7-1/2"	1.13	2	
0323	B-17	2-3/4"	3/4"	8-1/2"	1.21	2	
0324	B-18	2-3/4"	3/4"	12"	1.63	2	
0286	B-27	1-1/8"	7/8"	12"	1.07	2	

STRIKE-GUARD MERCHANDISER (RACK ONLY) STOCK #8155

**ENDERES TOOL COMPANY** was founded in Albert Lea, Minnesota in 1911, the result of a merger between Albert Lea Machinery Company, which was founded in 1908 in Albert Lea, Minnesota, by Joe Pihl; and Enderes Manufacturing Company, which was founded in 1896 in Littleport, Iowa and was owned by Ernst Enderes. Enderes Manufacturing Company produced three tools – a 14" cutting nipper, a staple puller, and a drop forged cold chisel. The Albert Lea Machinery Company sold those three tools for Enderes Manufacturing Company. Sales soon outstripped production capabilities, and an expansion was required. The entire operation was relocated to a new plant in Albert Lea, Minnesota. The old octagon tool plant burned to the ground in 1966, and we built our present plant. Enderes has always been a family-held corporation. You can count on one hand, the tool companies in America that have had that long a life span that are still owned and operated by the same family. We take pride in that!

## SUPERIOR QUALITY PUNCHES & NAIL SETS

- **Finest Grade Tool Steel**
- **Deep Tempered – Exclusive with Enderes®!**



### USE

Punches are designed to punch holes in metal and other materials, mark metals, drive or remove pins and rivets, and align holes in different sections of metal. Punches are designed for use on metals softer than the punch itself and should never be used on stone or concrete.

Strike the face of the punch squarely with a ball pein or machinists hammer. Never strike with a nail hammer. Always strike the punch with a light, cautious blow when starting a job to determine the relative hardness of the material being punched. Always wear safety goggles when using a punch.

### SELECTION

Punches are classified by the shape of the taper and point. Center and Prick Punches have a sharp point for precise markings. Enderes® Center Punches are available in 7 different sizes and lengths. Enderes® Prick Punches are available in 3 sizes ranging in stock sizes from 1/4" to 1/2". Solid Punches are used before using a Pin Punch to start a pin. Enderes® Solid Punches are available in 11 sizes from 1/16" to 1/2". Pin Punches have a flat point and consistent taper and are used to remove pins and rivets. Enderes® Pin Punches are available in 16 different sizes with points ranging from 1/16" to 5/8". Alignment Punches have a long taper and flat point and are used to align holes in different

sections of metal. Enderes® Alignment Punches come in 8 different sizes with points ranging from 1/8" to 3/8".

### MAINTENANCE

A dull cutting edge may be sharpened using a common file as described in our "Maintenance" section below:

1. Always wear safety goggles when sharpening a cutting edge and when ever using a striking tool.
2. Rigidly support the tool being sharpened. Secure in a bench vise if possible.
3. Never use grinding to sharpen. This causes excessive heat and may result in a loss of strength, durability and temper.
4. Instead, use a file or stone of medium or fine grit and file away from the cutting edge. This directs heat away from the edge.
5. The original contour of the cutting edge or point should be restored. Prick Punches should be restored to 30 de-grees and Center Punches should be restored to 60 degrees. Pin, Rivet, and Alignment Punches - flat and square with axis of tool.

Discard any punch if it is bent or show dents, cracks, chips, mushrooming, or excessive wear.

### SPECIFICATION

Enderes Tools® Punches are forged, heat treated, and polished, using only domestic high carbon tool steel. They meet all applicable ANSI and ASTM steel standards for materials, physical properties and testing, including A29-9, A322-79A, A331-74 (1979), A576-79, and A681-76. All styles of Enderes® Punches fall within the appropriate Rockwell hardness range recommended by ANSI and ASTM for their intended application.

## OPEN STOCK PUNCHES

### SOLID PUNCHES

This tool is used as a starter punch before using the Pin Punch. The taper gives it extra strength. Domestic high carbon tool steel and individually heat treated to insure maximum strength and toughness.



Bulk Stk #	Carded Stk #	Description	Cut/Pt.	Stock Size	Overall Length	Weight Bulk/Carded	Std. Pkg.
0044	0630	B-1	1/16"	3/16"	4"	0.03/0.05	6
0047	0631	B-2	3/32"	1/4"	4-1/2"	0.06/0.07	6
0050	0633	B-3	1/8"	5/16"	5"	0.09/0.11	6
0053	0639	B-4	1/8"	3/8"	5-1/2"	0.15/0.17	6
0056	0642	B-5	5/32"	3/8"	5-1/2"	0.15/0.16	6
0059	0645	B-6	3/16"	3/8"	5-1/2"	0.16/0.18	6
0062	0646	B-7	3/16"	1/2"	7"	0.32/0.35	6
0065	0649	B-77	1/4"	1/2"	7"	0.35/0.38	6
0066	*	B-78	5/16"	1/2"	7"	0.36/ *	6
0067	0652	B-8	3/8"	5/8"	9"	0.69/0.72	6
0269	*	B-31	1/2"	7/8"	18"	2.00/ *	6

### PIN PUNCHES

This tool is used for driving a pin out after it has been started with a Solid Punch. Domestic high carbon tool steel and individually heat treated to insure maximum strength and toughness.



Bulk Stk #	Carded Stk #	Description	Cut/Pt.	Stock Size	Overall Length	Weight Bulk/Carded	Std. Pkg.
0076	0655	C-1	1/16"	3/16"	4"	0.03/0.05	6
0079	0657	C-2	3/32"	1/4"	4-1/2"	0.05/0.06	6
0082	0661	C-3	1/8"	5/16"	5"	0.08/0.11	6
0085	0664	C-4	1/8"	3/8"	5-1/2"	0.13/0.16	6
0088	0667	C-5	5/32"	3/8"	5-1/2"	0.14/0.16	6
0091	0668	C-6	3/16"	3/8"	5-1/2"	0.13/0.16	6
0094	0669	C-7	13/64"	7/16"	6"	0.21/0.23	6
0097	0670	C-8	3/16"	1/2"	7"	0.28/0.31	6
0100	0674	C-88	1/4"	7/16"	7"	0.26/0.28	6
0101	0675	C-89	5/16"	1/2"	7"	0.34/0.36	6
0102	0677	C-9	3/8"	5/8"	9"	0.68/0.45	6

### LONG PIN PUNCHES - 4" PIN

Forged from domestic high carbon tool steel and individually heat treated to insure maximum strength and toughness.



Bulk Stk #	Carded Stk #	Description	Cut/Pt.	Stock Size	Overall Length	Weight Bulk/Carded	Std. Pkg.
0326	*	C-11A	1/8"	5/16"	8-1/2"	0.11	6
0325	0701	C-11	3/16"	3/8"	8-1/2"	0.18/0.21	6
0328	0702	C-12	1/4"	7/16"	8-1/2"	0.27/0.30	6
0331	*	C-13	5/16"	1/2"	8-1/2"	0.35	6
0334	*	C-14	3/8"	5/8"	8-1/2"	0.56	6

### ROLL PIN PUNCHES

Used for driving out and removing spring pins. This tool knurled for ease in gripping. Individually heat treated for maximum strength.



Bulk Stk #	Carded Stk #	Description	Cut/Pt.	Stock Size	Overall Length	Weight Bulk/Carded	Std. Pkg.
**	0740	C-16	1/8"	1/4"	4"	**/0.03	6
**	0741	C-17	5/32"	1/4"	4-1/2"	**/0.04	6
**	0742	C-18	3/16"	5/16"	4-1/2"	**/0.08	6
**	0743	C-19	7/32"	5/16"	5"	**/0.09	6
**	0744	C-20	1/4"	3/8"	5-1/2"	**/0.13	6

### ALIGNMENT PUNCHES

Also known as Drift Punches. Used to lineup the holes in two pieces of equipment, steel buildings, etc. Insert this long punch into both holes and pry or twist both holes into alignment, then tap gently and its long, even taper will force the holes into perfect alignment.



Bulk Stk #	Carded Stk #	Description	Cut/Pt.	Stock Size	Overall Length	Weight Bulk/Carded	Std. Pkg.
0117	0712	D-5	1/8"	3/8"	9"	0.21/0.24	6
0120	0715	D-6	5/32"	1/2"	10"	0.45/0.48	6
0123	0718	D-7	3/16"	5/8"	11"	0.77/0.80	6
0126	0721	D-8	1/4"	3/4"	12"	1.18/1.21	6
0127	0724	D-88	5/16"	3/4"	14"	1.47/1.52	6
0128	*	D-89	3/8"	3/4"	14"	1.53/ *	6

\* Not available Carded. \*\* Not available Bulk

### EXTRA LONG ALIGNMENT PUNCHES

For the hard to reach job. 18" overall length.



Bulk Stk #	Carded Stk #	Description	Cut/Pt.	Stock Size	Overall Length	Weight Bulk/Carded	Std. Pkg.
0277	*	D-10	1/4"	3/4"	18"	1.97/ *	6
0266	*	B-30	1/4"	3/4"	12"	1.66/ *	6

### CENTER PUNCHES

Makes accurate hole starting easier. Extra sharp point assures long tool life. Forged from domestic steel and individually heat treated.



Bulk Stk #	Carded Stk #	Description	Cut/Pt.	Stock Size	Overall Length	Weight Bulk/Carded	Std. Pkg.
0160	0753	F-1	7/32"	3/8"	4-1/2"	0.13/0.16	6
0163	0756	F-2	17/64"	1/2"	4-1/2"	0.23/0.26	6
0164	0759	F-2A	17/64"	1/2"	6"	0.33/0.33	6
0166	0755	F-3	7/32"	3/8"	5-1/2"	0.17/0.17	6
0158	0751	F-25	1/8"	1/4"	4-1/2"	0.06/0.08	6
0159	0752	F-26	1/8"	5/16"	5"	0.06/0.08	6
0168	*	F-27	1/2"	5/8"	6"	0.52/ *	6

### PRICK PUNCHES

This tool is used for scribing or scratching into metal or steel for marking or layout work. Extra sharp point for long tool life.



Bulk Stk #	Carded Stk #	Description	Cut/Pt.	Stock Size	Overall Length	Weight Bulk/Carded	Std. Pkg.
0172	0768	F-5	7/32"	3/8"	4-1/2"	0.13/0.16	6
0175	0771	F-6	7/32"	3/8"	5-1/2"	0.23/0.26	6
0171	0766	F-29	1/8"	5/16"	5"	0.33/0.33	6

## PIN PUNCH DISPLAY

### #439 PIN PUNCH COUNTER DISPLAY

Compact 5" W x 12" D counter or shelf display. Displays 39 total Pin Punches. Nice profit center!



#439 PIN PUNCH COUNTER DISPLAY STOCK #0592

#439 PIN PUNCH COUNTER DISPLAY (BOARD ONLY) STOCK #0536

Bulk Stk #	Description	Cut/Pt.	Size	Stock Length	Overall Wt.	Std. Pkg.
0076	C-1	1/16"	3/16"	4"	0.02	3
0079	C-2	3/32"	1/4"	4-1/2"	0.05	3
0082	C-3	1/8"	5/16"	5"	0.87	3
0085	C-4	1/8"	3/8"	5-1/2"	0.13	3
0088	C-5	5/32"	3/8"	5-1/2"	0.14	3
0091	C-6	3/16"	3/8"	5-1/2"	0.13	3
0094	C-7	13/64"	7/16"	6"	0.21	3
0097	C-8	3/16"	1/2"	7"	0.28	3
0100	C-88	1/4"	7/16"	7"	0.33	3
0101	C-89	5/16"	1/2"	7"	0.77	3
0102	C-9	3/8"	5/8"	9"	0.68	3
0325	C-11	3/16"	3/8"	8-1/2"	0.18	2
0328	C-12	1/4"	7/16"	8-1/2"	0.27	2
0331	C-13	5/16"	1/2"	8-1/2"	0.35	2

*We have committed ourselves to produce only the finest quality struck hand tools. This commitment and dedication to quality craftsmanship and manufacturing techniques should make you feel very confident when you sell Enderes Tools.*

## PIN PUNCH SETS AND ROLLS

### SET #6 - PIN PUNCH

Four of our most popular pin punch sizes in a re-closeable pouch.

PIN PUNCH SET #6  
STOCK #0515

Bulk Stk #	Description	Cut/Pt.	Stock Size	Overall Length	Wt.	Std. Pkg.
0079	C-2	3/32"	1/4"	4-1/2"	0.05	1
0085	C-4	1/8"	3/8"	5-1/2"	0.14	1
0088	C-5	5/32"	3/8"	5-1/2"	0.14	1
0091	C-6	3/16"	3/8"	5-1/2"	0.14	1



### SET #7 - ALIGNMENT PUNCHES

Alignment punches in three sizes that will cover most everyday jobs in a reclosable pouch.

ALIGNMENT PUNCHES SET #7  
STOCK #0518

Bulk Stk #	Description	Cut/Pt.	Stock Size	Overall Length	Wt.	Std. Pkg.
0117	D-5	1/8"	3/8"	9"	0.21	1
0120	D-6	5/32"	1/2"	10"	0.45	1
0123	D-7	3/16"	5/8"	11"	0.77	1



### SET #8 - LONG PIN PUNCHES

Long Pin Punches in three popular sizes. Heavy vinyl pouch.

LONG PIN PUNCH SET #8  
STOCK #0521

Bulk Stk #	Description	Cut/Pt.	Stock Size	Overall Length	Wt.	Std. Pkg.
0328	C-12	1/4"	7/16"	8-1/2"	0.27	1
0331	C-13	5/16"	1/2"	8-1/2"	0.35	1
0334	C-14	3/8"	5/8"	8-1/2"	0.56	1



### 5 PC. LONG PIN PUNCH ROLL

Our 5 most popular extra length pin punches in a re-useable roll-up pouch. With long 4" pin lengths, these special punches perform when others fall short. A "must" tool set for those who work with production equipment repair and maintenance.

5 PC. LONG PIN PUNCH ROLL  
STOCK #0539

Bulk Stk #	Description	Cut/Pt.	Stock Size	Overall Length	Wt.	Std. Pkg.
0326	C-11A	1/8"	5/16"	8-1/2"	0.11	1
0325	C-11	3/16"	3/8"	8-1/2"	0.18	1
0328	C-12	1/4"	7/16"	8-1/2"	0.27	1
0331	C-13	5/16"	1/2"	8-1/2"	0.35	1
0334	C-14	3/8"	5/8"	8-1/2"	0.56	1



### 5 PC. ROLL PIN PUNCH SET

The tool to use when driving out and removing spring pins. Our Roll Pin Punches are knurled for greater ease in gripping. Set holds one each with cut point sizes of 1/8", 5/32", 3/16", 7/32" and 1/4".

5 PC. ROLL PIN PUNCH SET  
STOCK #0525

Cd. 5 PC. ROLL PIN PUNCH SET  
STOCK #0528

Bulk Stk #	Description	Cut/Pt.	Stock Size	Overall Length	Wt.	Std. Pkg.
0740	C-16	1/8"	1/4"	4"	0.47	1
0741	C-17	5/32"	1/4"	4-1/2"	0.57	1
0742	C-18	3/16"	5/16"	4-1/2"	0.88	1
0743	C-19	7/32"	5/16"	5"	0.07	1
0744	C-20	1/4"	3/8"	5-1/2"	0.11	1



### 6 PC. PIN PUNCH ROLL

Five popular Pin Punch sizes in a heavy vinyl tool roll.

6 PC. PIN PUNCH ROLL  
STOCK #0530

Cd. 6 PC. PIN PUNCH ROLL  
STOCK #0534

Bulk Stk #	Description	Cut/Pt.	Stock Size	Overall Length	Wt.	Std. Pkg.
0079	C-2	3/32"	1/4"	4-1/2"	0.05	2
0085	C-4	1/8"	3/8"	5-1/2"	0.13	1
0091	C-6	3/16"	3/8"	5-1/2"	0.13	1
0100	C-88	1/4"	7/16"	7"	0.33	1
0088	C-5	5/32"	3/8"	5-1/2"	0.14	1



## NAIL SETS

Machined from very high carbon tool steel individually heat treated for long life. Used for recessing nails into wood, etc. Hex head reduces rolling when tool is laid down. 4 point sizes available. Available carded only.

Cd Stk #	Description	Cut/Pt.	Stock Size	Overall Length	Wt.	Std. Pkg.
0754	Nail Set 1	1/32"	3/8"	4"	0.20	6
0757	Nail Set 2	2/32"	3/8"	4"	0.20	6
0760	Nail Set 3	3/32"	3/8"	4"	0.20	6
0758	Nail Set 4	4/32"	3/8"	4"	0.20	6
0761	Combo Kit-includes one each 1/32", 2/32", 3/32"				0.60	6



## PUNCH MERCHANDISERS

### CENTER & PRICK PUNCH MERCHANDISER

Compact and attractive display which combines the best selling Center and Prick Punches. 15" W x 11-1/2" H. 21 total pieces - 7 different tools. Display includes tool hangers.



Cd Stk #	Description	Cut/Pt.	Stock Size	Overall Length	Wt.	Std. Pkg.
0751	F-25	1/8"	1/4"	4-1/2"	0.08	3
0752	F-26	1/8"	5/16"	5"	0.08	3
0753	F-1	7/32"	3/8"	4-1/2"	0.16	3
0756	F-2	17/64"	1/2"	4-1/2"	0.26	3
0766	F-29	1/8"	5/16"	5"	0.08	3
0768	F-5	7/32"	3/8"	4-1/2"	0.15	3
0771	F-6	7/32"	3/8"	5-1/2"	0.20	3

Cd. CENTER & PRICK PUNCH MERCHANDISER  
STOCK #0889

Cd. CENTER & PRICK PUNCH MERCHANDISER (RACK ONLY)  
STOCK #8110

### STARTING & PIN PUNCH MERCHANDISER

Displays full range of Starting and Pin Punches which are very popular with the DIY'R. 9-1/2" W x 13-1/2" H. Includes tool hangers. 27 pieces total - 9 different tools.



Cd Stk #	Description	Cut/Pt.	Stock Size	Overall Length	Wt.	Std. Pkg.
0630	B-1	1/16"	3/16"	4"	0.05	3
0639	B-4	1/8"	3/8"	5-1/2"	0.17	3
0645	B-6	3/16"	3/8"	5-1/2"	0.18	3
0649	B-77	1/4"	1/2"	7"	0.38	3
0655	C-1	1/16"	3/16"	4"	0.05	3
0661	C-3	1/8"	5/16"	5"	0.11	3
0664	C-4	1/8"	3/8"	5-1/2"	0.16	3
0668	C-6	3/16"	3/8"	5-1/2"	0.16	3
0674	C-88	1/4"	7/16"	7"	0.28	3

Cd. STARTING & PIN PUNCH MERCHANDISER  
STOCK #0893

Cd. STARTING & PIN PUNCH MERCHANDISER (RACK ONLY)  
STOCK #8115

## NAIL SET MERCHANDISER

This attractive merchandiser displays 15 total pieces - 4 different sizes. These Nail Sets represent the finest quality and best value in the industry today. 13" W x 9" H, comes complete with tool hangers.



Cd Stk #	Description	Cut/Pt.	Stock Size	Overall Length	Wt.	Std. Pkg.
0754	Nail Set 1	1/32"	3/8"	4"	0.20	3
0757	Nail Set 2	2/32"	3/8"	4"	0.20	3
0760	Nail Set 3	3/32"	3/8"	4"	0.20	3
0758	Nail Set 4	4/32"	3/8"	4"	0.20	3
0761	Combo Kit-includes one each of 1/32", 2/32", 3/32"				0.60	3

Cd. NAIL SET MERCHANDISER  
STOCK #0764

Cd. NAIL SET MERCHANDISER (RACK ONLY)  
STOCK #8145

## SUPERIOR QUALITY STAR DRILLS & SCREW EXTRACTORS

- *Finest Grade Tool Steel*
- *Deep Tempered – Exclusive with Enderes®!*



### USE

Star Drills are the forerunners of today's electric masonry drill bits. They are designed to create holes in masonry, brick, stone, and concrete. Star Drills are for hand use only. They are not to be used in power drilling equipment. The Star Drill cutting edge resembles four chisels joined at their edges to form a cross.

They are most often used today to supplement power drilling equipment. Star Drills easily cut through hard rocks, agates, and other hard materials encountered in masonry which can destroy electric masonry drill bits. Star Drills should be struck squarely with a hand drilling hammer. Never strike with a nail hammer and never use on anything but masonry. Always wear safety goggles when using Star Drills.

A Screw Extractor is used to remove screws, bolts, and other metal fasteners which are damaged or otherwise inaccessible through usual extraction methods.

A guide hole is drilled into the top of the fastener to be removed. The Screw Extractor is then driven into the fastener head with a ball peen or machinists hammer and turned counter-clockwise until the fastener is removed. Be sure to select a screw extractor of the appropriate size, just as you would match a screwdriver tip to the size and shape of the screw recess.

Never strike a Screw Extractor with a nail hammer and always wear safety goggles when using one.

### SELECTION

Enderes Tools® Star Drills are available in 5 different sizes and lengths with cut points ranging from 3/8" to 1". Enderes® Screw Extractors are available in 9 different sizes and lengths with point sizes ranging from 3/32" thru 5/8".

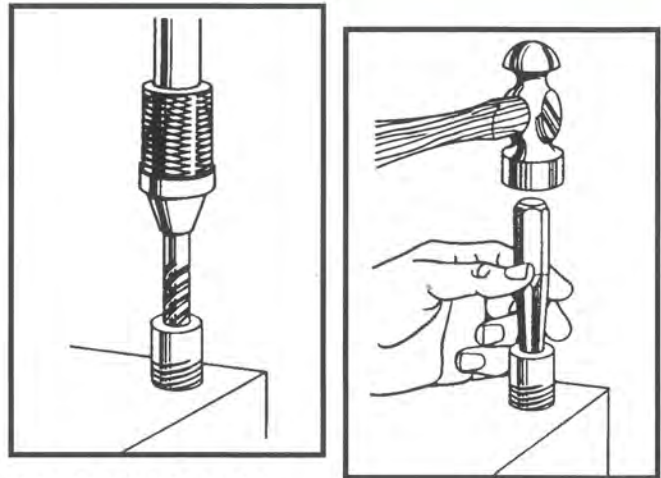

### MAINTENANCE

A Star Drill's dull cutting points may be sharpened using a common file. Be sure to maintain the original bevel. Star Drills should be discarded if they have chipped, battered, or mushroomed heads. Enderes® Screw Extractors may be redressed using a common file. Discard any Screw Extractor that is bent or shows dents, cracks, chips, or mushrooming.

### SPECIFICATION

Enderes Tools® Star Drills resist chipping and mushrooming longer than other Star Drills because they're forged, heat treated, and precision pointed. Enderes® Screw Extractors are the only forged, straight flute extractors available, so they will perform where machined or spiral-type extractors fail. In addition the tapered and straight flutes will not damage the object being removed. Enderes® Star Drills and Screw Extractors conform to all applicable ANSI and ASTM steel standards for materials, physical properties, and testing. Rockwell hardness range is C57-59.

## OPEN STOCK STAR DRILLS

Enderes® Star Drills are unique in that their flutes are the same diameter for the entire length. The flutes are extra long, allowing for many re-sharpenings with a file for exceptional tool life. No other Star Drills compare. Used for drilling holes in concrete, stone, brick, and any other similar materials. Individually heat treated and forged from the finest domestic high carbon tool steel.



Bulk Stk #	Carded Stk #	Description	Cut/Pt.	Stock Size	Overall Length	Weight Bulk/Carded	Std. Pkg.
0183	0777	F-8	3/8"	5/16"	12"	0.26/0.30	6
0186	0780	F-9	1/2"	3/8"	12"	0.38/0.42	6
0189	0783	F-10	5/8"	1/2"	12"	0.66/0.70	6
0192	0786	F-11	3/4"	5/8"	12"	1.02/1.06	6
0225	0828	F-14	1"	3/4"	12"	1.47/1.51	6

## SCREW EXTRACTORS

### OPEN STOCK SCREW EXTRACTORS

5 piece Extractor Set in a heavy gauge vinyl pouch. Includes our most popular sizes. Drill size for each extractor marked on the kit. Exceptional strength in these tools.



Bulk Stk #	Carded Stk #	Description	Cut/Pt.	Stock Size	Overall Length	Weight Bulk/Carded	Std. Pkg.
0236	0703	S-1	1/8"	3/16"	2-1/2"	0.03/0.07	6
0239	0704	S-2	11/64"	1/4"	2-3/4"	0.04/0.08	6
0242	0705	S-3	7/32"	5/16"	3"	0.06/0.09	6
0245	0706	S-4	9/32"	3/8"	3-1/4"	0.10/0.13	6
0248	0707	S-5	21/64"	7/16"	3-1/2"	0.11/0.14	6
0251	0708	S-6	7/16"	1/2"	4-1/2"	0.21/0.24	6
0254	0709	S-7	1/2"	5/8"	5"	0.38/0.41	6
0257	0710	S-8	9/16"	3/4"	5-1/4"	0.53/0.56	6
0260	0711	S-9	5/8"	7/8"	5-1/2"	0.73/0.76	6

### SCREW EXTRACTOR KIT

5 piece Extractor Set in a heavy gauge vinyl pouch. Includes our most popular sizes. Drill size for each extractor marked on the kit. Exceptional strength in these tools.

#9 SCREW EXTRACTOR KIT STOCK #0524



Bulk Stk #	Description	Cut/Pt.	Stock Size	Overall Length	Wt.	Std. Pkg.
0236	S-1	1/8"	3/16"	2-1/2"	0.03	1
0239	S-2	11/64"	1/4"	2-3/4"	0.04	1
0242	S-3	7/32"	5/16"	3"	0.06	1
0245	S-4	9/32"	3/8"	3-1/4"	0.10	1
0248	S-5	21/64"	7/16"	3-1/2"	0.11	1

### Drill Guide For Enderes® Screw Extractors

ENDERES® NUMBER	POINT SIZE	DRILL TO USE	ENDERES® NUMBER	POINT SIZE	DRILL TO USE
S-1	1/8"	5/32"	S-6	7/16"	1/2"
S-2	11/64"	3/16"	S-7	1/2"	9/16"
S-3	7/32"	15/64"	S-8	9/16"	5/8"
S-4	9/32"	5/16"	S-9	5/8"	11/16"
S-5	21/64"	3/8"			

## SCREW EXTRACTORS DISPLAY

### #14 SCREW EXTRACTOR COUNTER DISPLAY

Compact 3-1/8" W x 12" D counter or shelf display. 9 different sizes of extractors, 21 tools in all. Great profit center.



Bulk Stk #	Description	Cut/Pt.	Stock Size	Overall Length	Wt.	Std. Pkg.
0236	S-1	1/8"	3/16"	2-1/2"	0.03	3
0239	S-2	11/64"	1/4"	2-3/4"	0.50	3
0242	S-3	7/32"	5/16"	3"	0.06	3
0245	S-4	9/32"	3/8"	3-1/4"	0.10	3
0248	S-5	21/64"	7/16"	3-1/2"	0.22	3
0251	S-6	7/16"	1/2"	4-1/2"	0.21	3
0254	S-7	1/2"	5/8"	5"	0.38	1
0257	S-8	9/16"	3/4"	5-1/4"	0.53	1
0260	S-9	5/8"	7/8"	5-1/2"	0.73	1

#14 SCREW EXTRACTOR COUNTER DISPLAY STOCK #0558

#14 SCREW EXTRACTOR COUNTER DISPLAY (BOARD ONLY) STOCK #0555

## SCREW EXTRACTOR MERCHANDISERS

Made from the highest quality domestic tool steel, Enderes® Screw Extractors are the only forged straight flute extractors available on the market today. They are superior to other types because they will not chew up or expand the object being removed. The four straight chisel edges can be driven solidly into work to insure easy removal of broken objects. Gradual taper will not wedge or bind. Used to remove broken screws, studs, bolts, pipe fittings, etc.



Carded Stk #	Description	Cut/Pt.	Stock Size	Overall Length	Wt.	Std. Pkg.
0703	S-1	1/8"	3/16"	2-1/2"	0.07	3
0704	S-2	11/64"	1/4"	2-3/4"	0.53	3
0705	S-3	7/32"	5/16"	3"	0.09	3
0706	S-4	9/32"	3/8"	3-1/4"	0.13	3
0707	S-5	21/64"	7/16"	3-1/2"	0.25	3
0708	S-6	7/16"	1/2"	4-1/2"	0.24	2
0709	S-7	1/2"	5/8"	5"	0.41	2
0710	S-8	9/16"	3/4"	5-1/4"	0.53	2
0711	S-9	5/8"	7/8"	5-1/2"	0.76	2

Cd. SCREW EXTRACTOR MERCHANDISER STOCK #0884

Cd. SCREW EXTRACTOR MERCHANDISER (RACK ONLY) STOCK #9135

## STAR DRILL MERCHANDISER

15 total Star Drills displayed on this wall merchandiser. 15" W x 18" H. 3 each of the 5 most common sizes. Tool hangers included. Due to their long, straight flutes, Enderes® Star Drills are nationally recognized as the finest available on the market today.



Cd. STAR DRILL MERCHANDISER STOCK #0891

Cd. STAR DRILL MERCHANDISER (RACK ONLY) STOCK #8120

Carded Stk #	Description	Cut/Pt.	Stock Size	Overall Length	Wt.	Std. Pkg.
0777	F-8	3/8"	5/16"	12"	0.03	3
0780	F-9	1/2"	3/8"	12"	0.42	3
0783	F-10	5/8"	1/2"	12"	0.70	3
0786	F-11	3/4"	5/8"	12"	1.06	3
0828	F-14	1"	3/4"	12"	1.51	3

**SINCE 1896**, the primary thrust of Enderes Tool Company has been to produce only the highest quality Struck Hand Tools. We can document and illustrate that all of our tools exceed any written specifications that have ever been generated on struck tools. One of the keys to quality is the utilization of time-honored manufacturing techniques. These "Blacksmith" techniques impart a quality to struck tools, which cannot be obtained with some of the modern mass production techniques utilized by our competitors.

**ENDERES TOOLS**

**QUALITY FORGED HAND TOOLS FOR A LIFETIME.**

## SUPERIOR QUALITY BARS

- *Finest Grade Tool Steel*
- *Deep Tempered – Exclusive with Enderes®!*



### **USE**

Pry Bars, Ripping Bars and Nail Pullers are used in construction and demolition when pulling nails, ripping wood, prying moulding and similar tasks are done. Their length and shape provide greater leverage than claw hammers and other striking tools which are not designed for prying.

Never strike the claw, or working portion, of the bar. The claw is not designed to withstand such a blow and the bar may fracture. Always wear safety goggles when using these bars.

### **SELECTION**

Most bars come as combination tools with two different end styles. This provides versatility in meeting job demands. Features usually include an extended body and a combo of either a tapered end, a nail claw or a nail pulling slot.

Longer and more sharply curved bars provide the greatest leverage for the toughest jobs

### **MAINTENANCE**

Discard any bar that is bent or has a chipped, broken claw, or rounded or dull bevel.

### **SPECIFICATION**

Since Enderes® Bars are forged only from domestic high carbon tool steel, heat treated and polished, they will resist excessive wear more effectively than any other bar. They conform to all applicable ANSI and ASTM steel standards for materials, physical properties and testing, including A-29-79, A332-80, A331-79, A576-79, and A681-76. All styles fall within the appropriate Rockwell hardness ranges recommended by ANSI and ASTM for their intended applications.

**PHONE: 800-874-7776**  
**FAX: 507-373-2398**

## OPEN STOCK BARS

### D-13 PRY BAR

Made from the highest quality tool steel available. This bar may be only 12" long but the offset in the neck enables you to achieve compound leverage. The slot is large enough to handle 30 penny nails! Made from 5/8" stock.



Bulk Stk #	Description	Stock Size	Overall Length	Wt.	Std. Pkg.
0289	D-13	5/8"	12"	1.20	6

### D-14 RIPPING BAR

Made from the highest quality tool steel available. This single end bar is forged from heavier stock than most competitors. It is used primarily for tearing, prying, and removing such things as floor tile, wall paneling, etc. Made from 3/4" stock with an overall length of 18".



Bulk Stk #	Description	Stock Size	Overall Length	Wt.	Std. Pkg.
0292	D-14	3/4"	18"	2.30	6

### D-15 DOUBLE END RIPPING BAR

Made from the highest quality tool steel available. Both working ends of this bar are completely forged and heat treated. It too, is made from 3/4" stock (most other bars on the market are made from 5/8" stock). The bent leg of this tool is longer than similar bars of its kind for increased leverage.



Bulk Stk #	Description	Stock Size	Overall Length	Wt.	Std. Pkg.
0295	D-15	3/4"	18"	2.53	6

### D-16 SPRING STEEL RIPPING BAR

Both ends of this bar are forged and heat treated. Our stock is wider and thicker than other bars on the market. The offset at the bent end makes this the ideal tool for hanging doors. Has an overall length of 14".



Bulk Stk #	Description	Stock Size	Overall Length	Wt.	Std. Pkg.
0298	D-16	1-1/2"	14"	1.57	6

### D-21 SINGLE END NAIL PULLER

This Cats Paw type puller will easily handle a 30 penny nail. This tool is heavier than most on the market.



Bulk Stk #	Description	Stock Size	Overall Length	Wt.	Std. Pkg.
0315	D-21	5/8"	10"	1.10	6

### D-22 MINI BAR

This bar can be used in all applications that our D-16 Spring Steel bar is used. The bar has an overall length of 9-1/2".



Bulk Stk #	Description	Stock Size	Overall Length	Wt.	Std. Pkg.
0318	D-22	1-1/2"	9-1/2"	0.40	6

### D-23 COMBINATION TOOL

Made from the highest quality tool steel available. This double ended bar combines the valuable Cats Paw type puller with the useful pry bar qualities. Made from 5/8" stock with an overall length of 15".



Bulk Stk #	Description	Stock Size	Overall Length	Wt.	Std. Pkg.
0316	D-23	5/8"	15"	1.53	6

### D-24 DOUBLE ENDED NAIL PULLER

Made from the highest quality tool steel. This tool is a double ended Cats Paw type tool. Both ends allow you the flexibility to pull headless nails up to 30 penny at almost any angle! Fully forged and heat treated. 5/8" stock with overall length of 10-1/2".



Bulk Stk #	Description	Stock Size	Overall Length	Wt.	Std. Pkg.
0317	D-24	5/8"	10-1/2"	1.07	6

### D-26 MOULDING TOOL

This double ended bar is invaluable for removing corner and baseboard mouldings. Both ends are forged, heat treated, and polished. Made from 1/2" stock with an overall length of 10". No carpet layer should be without one!



Bulk Stk #	Description	Stock Size	Overall Length	Wt.	Std. Pkg.
0319	D-26	1/2"	10"	0.65	6

### D-36 MINI CHAMP BAR

Our D-36 Mini Champ Bar is identical in appearance to our D-16 Spring Steel Ripping Bar with only a 6" overall length. No home should be without one in their tool box or "junk" drawer. Ideal for opening, scraping, prying, and applying siding.



Bulk Stk #	Description	Stock Size	Overall Length	Wt.	Std. Pkg.
0302	D-36	1"	7-1/4"	0.30	6

### D-37 MICRO UTILITY BAR

This Micro Utility Bar looks just like our D16 Spring Steel Ripping Bar with only a 5-1/4" overall length. A must for every Toolbox and Utility drawer. Ideal for removing small tacks, brads and finishing nails.

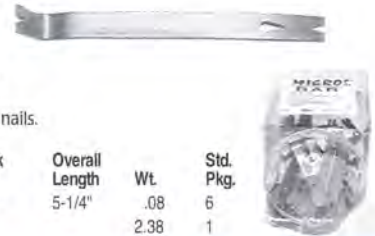

Bulk Stk #	Carded Stk#	Description	Stock Size	Overall Length	Wt.	Std. Pkg.
0300	0301	D-37	1/2"	5-1/4"	.08	6
0919	*	30 pc. Bowl			2.38	1

### HEAVY DUTY CONSTRUCTION BARS

Offset claw angle allows close quarter work. Heavy duty length for increased leverage.



Bulk Stk #	Description	Stock Size	Overall Length	Wt.	Std. Pkg.
0651	D-27	5/8"	14"	1.38	6
0653	D-28	7/8"	24"	4.5	6
0654	D-29	7/8"	30"	5.6	6

### MONSTER PAW BARS

Another Enderes first. A one of a kind combination offset claw angle for close quarter work and catspaw type design rotated 90 degrees for lower angle work. 3 different lengths to meet your needs.



Bulk Stk #	Description	Stock Size	Overall Length	Wt.	Std. Pkg.
0659	D-72	5/8"	12"	1.18	6
0663	D-82	5/8"	18"	1.76	6
0665	D-92	5/8"	24"	2.32	6

### WRECKING BARS

These "goose neck" style bars are forged from domestic carbon tool steel. The curved head end includes a slotted claw for removing nails while the "Pinch" end is like a flat chisel for prying and lifting. Available in 4 lengths from 18" to 36".



Bulk Stk #	Description	Pinch End	Stock Size	Overall Length	Wt.	Std. Pkg.
0650	D-30	7/8"	5/8"	18"	1.96	6
0656	D-33	1-1/16"	3/4"	24"	3.65	6

### ROLLING HEAD PRY BARS

The unique head design on this bar serves as a fulcrum providing additional leverage. Often used in close quarters or tight situations where the extra strength of the forged head is needed. The tapered, pointed end is used for aligning applications.



Bulk Stk #	Description	Stock Size	Overall Length	Wt.	Std. Pkg.
0678	D-17	7/16"	12"	0.43	6
0679	D-18	9/16"	16"	0.64	6
0680	D-19	11/16"	20"	0.80	6



### BENT TIP PRY BARS

Designed to perform the heavy duty leveraging and prying tasks where screwdrivers are too often misused. Forged and heat treated for toughness and durability. Large screwdriver type handles offer comfortable grip and aid in leverage potential.



In addition to the bent tip style bars, Enderes® offers an 18" screwdriver style blade. In addition to performing as a pry bar, this tool can double as an extra length screwdriver when needed.

Bulk Stk #	Description	Stock Size	Overall Length	WL	Std. Pkg.
0682	D-40	7/16"	7"	0.65	6
0684	D-41	7/16"	12"	0.91	6
0686	D-42	1/2"	18"	1.64	6
0688	D-43	1/2"	24"	2.01	6
0690	D-44 (Straight)	1/2"	18"	1.60	6

### D-16P SPRING STEEL RIPPING PROMO BAR

Like our professional quality D-16 Ripping Bar, both ends of this promotional bar are forged and heat treated. It is larger overall than most of our competitors. Priced to compete against other "promotional" bars, as always, you get more for your money with an Enderes®, Black oxide finish.



Bulk Stk #	Description	Stock Size	Overall Length	Wt.	Std. Pkg.
3006	D-16P	1-1/2"	14"	1.57	6

## BAR MERCHANDISER

36 total bars. This merchandiser mounts on pegboard to display 9 of the finest quality, fastest selling bars available. Measures only 24" W. x 18"H., it provides an effective and attractive way to consolidate and promote product.



#736 BAR WALL MERCHANDISER STOCK #0596

#736 BAR WALL MERCHANDISER (RACK ONLY) STOCK #0556

Bulk Stk #	Description	Stock Size	Overall Length	Wt.	Std. Pkg.
0292	D-14	3/4"	18"	2.30	4
0295	D-15	3/4"	18"	2.53	4
0298	D-16	1-1/2"	14"	1.57	4
0315	D-21	5/8"	10"	1.10	4
0316	D-23	5/8"	15"	1.53	4
0317	D-24	5/8"	10-1/2"	1.07	4
0319	D-26	1/2"	10"	0.65	4
0650	D-30	5/8"	18"	1.96	4
0656	D-33	3/4"	24"	3.65	4

### #726 CONSTRUCTION BAR CENTER

Get your Construction Bars off the bottom shelf and hanging at eye level for maximum sales. The bars are attached to an attractive card that contains point of sale references and allow you to hang some construction bars that are not normally allowed to hang. All the tools are backed by a planogram that identifies the tools for reorder and also secures a permanent spot in your store.

When you reorder to refill your #726 Display, make sure to add the letter "C" to the standard bar part number. This will insure that you get the hang card, along with the proper bar.

Display measures 18" W x 22" H and contains 26 total tools made up of 8 different bars.

#726 WALL MERCHANDISER STOCK #0574

#726 WALL MERCHANDISER (DIAGRAM ONLY) STOCK #0549



Bulk Stk #	Description	Stock Size	Overall Length	Wt.	Std. Pkg.
C0653	D28 Monster Bar	7/8"	24"	4.50	2
C0654	D29 Monster Bar	7/8"	30"	5.60	2
C0659	D72 Monster Paw	5/8"	12"	1.18	2
C0663	D82 Monster Paw	5/8"	18"	1.76	2
0298	D16 Ripping Bar	1-1/2"	14"	1.57	6
0318	D22 Mini Bar	1-1/2"	9-1/2"	0.40	6
C0319	D26 Moulding Bar	1/2"	10"	0.65	3
C0317	D24 Cats Paw	5/6"	10-1/2"	1.07	3

### ROLLING HEAD PRY BAR MERCHANDISER

This eye catching merchandiser mounts on pegboard and displays 2 each of our new forged Rolling Head Pry Bars.

Rolling Head Pry Bar Merchandiser Stock #0695

Rolling Head Pry Bar Merchandiser (RACK ONLY) Stock #0554



Bulk Stk #	Description	Stock Size	Overall Length	Wt.	Std. Pkg.
0678	D-17	7/16"	12"	0.43	2
0679	D-18	9/16"	16"	0.64	2
0680	D-19	11/16"	20"	0.80	2

### ROLLING HEAD PRY BAR KIT

1 each of the 12", 16" and 20" Rolling Head Bars packaged on an attractive Point-of Sale card.



3-PC. ROLLING HEAD PRY BAR KIT - STOCK #0681

## BENT TIP PRY BAR KIT

### 2-PC. BENT TIP PRY BAR KIT

This 2 piece set consists of 1 each of the 18" bent tip and 18" straight tip (screwdriver type) pry bars. This set offers the versatility of two tip styles along with the performance expected from these rugged tools.



2-PC. BENT TIP PRY BAR KIT - STOCK #0692

Bulk Stk #	Description	Stock Size	Steel Bar Length	Wt.	Std. Pkg.
0686	D-42	1/2"	18"	1.64	1
0690	D-44 (Straight)	1/2"	18"	1.59	1

### 3-PC. BENT TIP PRY BAR KIT

For the user who might not need the large 24" bar, Enderes® offers a 3 piece set in an eye-catching point-of-purchase box. This set contains 1 each of the 7", 12" and 18" bent tip bars.



3-PC. BENT TIP PRY BAR KIT - STOCK #0694

Bulk Stk #	Description	Stock Size	Steel Bar Length	Wt.	Std. Pkg.
0682	D-40	7/16"	7"	0.65	1
0684	D-41	7/16"	12"	0.88	1
0686	D-42	1/2"	18"	1.64	1

### 4-PC. BENT TIP PRY BAR KIT

All 4 of our popular bent tip bars packaged in a terrific point-of-purchase display box! This set comes complete with 1 each of the 7", 12", 18" and 24" bent tip bars.



4-PC. BENT TIP PRY BAR KIT - STOCK #0696

Bulk Stk #	Description	Stock Size	Steel Bar Length	Wt.	Std. Pkg.
0682	D-40	7/16"	7"	0.65	1
0684	D-41	7/16"	12"	0.88	1
0686	D-42	1/2"	18"	1.64	1
0688	D-43	1/2"	24"	2.01	1

## BENT TIP PRY BAR MERCHANDISER

This compact wall merchandiser provides an innovative and attractive way to display 2 each of all 5 of our Bent Tip Pry Bars. 10 total pieces, 13" W x 34" H. Tool hangers included.

BENT TIP PRY BAR MERCHANDISER STOCK #0698

BENT TIP PRY BAR MERCHANDISER (RACK ONLY) STOCK #8170

Bulk Stk #	Description	Stock Size	Steel Bar Length	Wt.	Std. Pkg.
0682	D-40	7/16"	7"	0.65	2
0684	D-41	7/16"	12"	0.88	2
0686	D-42	1/2"	18"	1.64	2
0688	D-43	1/2"	24"	2.01	2
0690	D-44 (Straight)	1/2"	18"	1.59	2



• **Finest Grade Tool Steel** • **Deep Tempered – Exclusive with Enderes®!**

## SUPERIOR QUALITY FARRIER TOOLS

### B-10 CUTTING NIPPER

Cut up to a 16 penny nail with this powerful little tool.



Bulk Stk #	Description	Overall Length	Weight	Std. Pkg.
0375	B-10 Cutting Nipper	10"	1.02	6
0378	Cushion Handled B-10	10"	1.07	6

### G-9 GOOSENECK NAIL CLINCHER

Drop forged for maximum toughness with milled teeth. Specially designed for use on ponies or low nails. 14" overall length.



Bulk Stk #	Description	Overall Length	Weight	Std. Pkg.
0417	G-9 Gooseneck Clincher	14"	1.18	6
0420	Cushion Handled G-9	14"	1.25	6

### C-10 CUTTING NIPPER

Cut up to a 20 penny nail with this powerful 14" overall length nipper.



Bulk Stk #	Description	Overall Length	Weight	Std. Pkg.
0381	C-10 Cutting Nipper	14"	1.65	6
0384	Cushion Handled C-10	14"	1.71	6

### G-2 BLACKSMITH'S TONG

A must for hot work. Drop forged. 14" overall length with a 1/4" grasp.



Bulk Stk #	Description	Overall Length	Weight	Std. Pkg.
0423	G-2 Blacksmith Tong	14"	1.07	6
0429	Cushion Handled G-2	14"	1.13	6

### C-10A FARRIERS PINCHER

Heavy Duty Pincher with a deep throat of 1-1/4". The only tool for pulling horse shoes and cutting excess length of Clinches. 14" overall length.



Bulk Stk #	Description	Overall Length	Weight	Std. Pkg.
0405	C-10A Farrier Pincher	14"	1.93	6
0408	Cushion Handled C-10A	14"	2.00	6

### G-4 CLINCH CUTTER

Dual purpose tool – Clinch Cutter or buffer on one end; pritchel on the other end. Has an overall length of 6".



Bulk Stk #	Description	Overall Length	Weight	Std. Pkg.
0435	G-4 Clinch Cutter	6"	0.43	6

### E-10 HOOF PARER

To be used on animal hoofs only! One jaw is blunt to serve as an anvil against which the sharpened jaw does the cutting. WILL NOT CUT NAILS. 14" overall length.



Bulk Stk #	Description	Overall Length	Weight	Std. Pkg.
0396	E-10 Hoof Parer	14"	1.67	6
0399	Cushion Handled E-10	14"	1.73	6

### G-5 PRITCHEL

Used for enlarging nail holes in horseshoes. Longer taper than most on the market. Forged for maximum strength. 9" overall length.



Bulk Stk #	Description	Overall Length	Weight	Std. Pkg.
0438	G-5 Pritchel	9"	0.66	6

### F-12 HOOF NIPPER

Jaws are sharpened only on the underside to allow cutting flush with the surface. To be used on animal hoofs only. Has a 14" overall length.



Bulk Stk #	Description	Overall Length	Weight	Std. Pkg.
0387	F-12 Hoof Nipper	14"	1.60	6
0390	Cushion Handled F-12	14"	1.66	6

### FARRIER BOOK

Text Book used in Farrier Science courses at leading Universities. Covers all phases from anatomy of the horse to corrective shoeing.



Bulk Stk #	Description	Weight	Std. Pkg.
1140	Farrier Book	1.46	1

## FARRIER TOOL MERCHANDISER

### #9 FARRIER TOOL MERCHANDISER

The most complete and compact Farrier Tool display in the industry today. This 24"W x 17"H merchandiser displays 10 different horseshoeing tools. Easy to mount and convenient to maintain, this display will sell Farrier Tools for you.



Bulk Stk #	Description	Overall Length	Wt.	Std. Pkg.
0381	C-10 Cutting Nipper	14"	1.65	2
0387	F-12 Hoof Nipper	14"	1.60	2
0396	E-10 Hoof Parer	14"	1.67	2
0405	C-10A Farriers Pincher	14"	1.93	1
0411	G-1 Nail Clincher	14"	1.18	1
0423	G-2 Blacksmith Tong	14"	1.07	1
0435	G-4 Clinch Cutter	6"	0.43	2
0438	G-5 Pritchel	9"	0.66	2

#9 FARRIER  
TOOL MERCHANDISER  
STOCK #0564

#9 FARRIER TOOL  
MERCHANDISER  
(BOARD ONLY)  
STOCK #0561

## HITCH PINS & HITCH PIN MERCHANDISER



### #23 HITCH PIN MERCHANDISER

This 18" W x 12" H merchandiser holds 23 total Hitch Pins, 7 different sizes. Tool hangers included.

#23 HITCH PIN MERCHANDISER  
STOCK #0573

#23 HITCH PIN MERCHANDISER  
(RACK ONLY) STOCK #0572



Bulk Stk #	Description	Working Length	Weight	Std. Pkg.
0355	H-00	3/8" x 3"	0.16	1
0357	H-0	1/2" x 3-1/2"	0.38	1
0359	H-1	5/8" x 4-1/2"	1.07	1
0361	H-2	3/4" x 6"	1.07	1
0363	H-3	7/8" x 6"	1.47	1
0365	H-4	1" x 6"	1.92	1
0367	H-5	1-1/8" x 7"	2.70	1

Bulk Stk #	Description	Overall Length	Weight	Std. Pkg.
0355	H-00	3/8" x 3"	0.16	3
0357	H-0	1/2" x 3-1/2"	0.38	3
0359	H-1	5/8" x 4-1/2"	1.07	6
0361	H-2	3/4" x 6"	1.07	6
0363	H-3	7/8" x 6"	1.47	3
0365	H-4	1" x 6"	1.92	1
0367	H-5	1-1/8" x 7"	2.70	1

## COMBINATION KITS & ROLLS

### SET #3 - COMBO PUNCH & CHISEL SET

An excellent struck tool kit for the average home, workshop, or DIY'R. 5 tools in a re-usable vinyl pouch.

STOCK #0507



	Bulk Stk #	Desc	Cut/Pt	Stock Size	Overall Length	Wt.	Std. Pkg.
COLD CHISELS	0013	A-5	1/2"	7/16"	5-3/4"	0.25	1
	0016	A-6	5/8"	1/2"	6"	0.75	1
	0059	B-6	3/16"	3/8"	5-1/2"	0.16	1
SOLID PUNCH	0091	C-6	3/16"	3/8"	5-1/2"	0.13	1
CENTER PUNCH	0160	F-1	7/32"	3/8"	4-1/2"	0.13	1

### SET #4 - COMBO PUNCH & CHISEL SET

This 6 piece set in a re-usable vinyl pouch is very popular with gunsmiths, etc. All six tools are the smallest in the industry – so small that other manufacturers do not attempt to make them.

STOCK #0510



	Bulk Stk #	Desc	Cut/Pt	Stock Size	Overall Length	Wt.	Std. Pkg.
COLD CHISELS	0001	A-1	1/4"	3/16"	4"	0.02	1
	0004	A-2	5/16"	1/4"	4-1/2"	0.06	1
SOLID PUNCHES	0044	B-1	1/16"	3/16"	4"	0.02	1
	0047	B-2	3/32"	1/4"	4-1/2"	0.06	1
PIN PUNCHES	0076	C-1	1/16"	3/16"	4"	0.02	1
	0079	C-2	3/32"	1/4"	4-1/2"	0.05	1

### 8 PC. PUNCH AND CHISEL ROLL

This versatile 8 piece set is a basic necessity for the beginning journeyman or maintenance worker. Packaged in a heavy duty roll-up pouch, this set offers: 3/8", 1/2" and 5/8" cut Cold Chisels; 3/16" Solid Punch; 1/8", 3/16", and 1/4" Pt. Pin Punches; and a hefty 1/2" stock Center Punch. Fits nicely into any tool chest drawer.

STOCK #0537



	Bulk Stk #	Description	Cut/Pt	Stock Size	Overall Length	Wt	Std. Pkg.
COLD CHISELS	0007	A-3	3/8"	5/16"	5"	0.11	1
	0013	A-5	1/2"	7/16"	5-3/4"	0.25	1
	0016	A-6	5/8"	1/2"	6"	0.37	1
SOLID PUNCH	0059	B-6	3/16"	3/8"	5-1/2"	0.16	1
PIN PUNCHES	0082	C-3	1/8"	5/16"	5"	0.08	1
	0091	C-6	3/16"	3/8"	5-1/2"	0.13	1
CENTER PUNCH	0100	C-88	1/4"	7/16"	7"	0.33	1
	0164	F-2A	7/64"	1/2"	6"	0.33	1

### 12 PC. PUNCH & CHISEL ROLL

12 piece Combination Punch & Chisel Roll consists of 3 chisels and various punches; Solid, Pin, Center, and Prick. Packaged in a heavy duty vinyl roll-up pouch for easy access, organization and storage. This 12 piece roll is toolbox size.

STOCK #0533



	Bulk Stk #	Description	Cut/Pt	Stock Size	Overall Length	Wt	Std. Pkg.
COLD CHISELS	0007	A-3	3/8"	5/16"	5"	0.11	1
	0013	A-5	1/2"	7/16"	5-3/4"	0.25	1
	0016	A-6	5/8"	1/2"	6"	0.37	1
SOLID PUNCHES	0053	B-4	1/8"	3/8"	5-1/2"	0.75	1
	0056	B-5	5/32"	3/8"	5-1/2"	0.15	1
	0059	B-6	3/16"	3/8"	5-1/2"	0.16	1
PIN PUNCHES	0085	C-4	1/8"	3/8"	5-1/2"	0.13	1
	0088	C-5	5/32"	3/8"	5-1/2"	0.14	1
	0091	C-6	3/16"	3/8"	5-1/2"	0.13	1
CENTER PUNCH	0160	F-1	7/32"	3/8"	4-1/2"	0.13	1
	0164	F-2A	17/64"	1/2"	6"	0.33	1
PRICK PUNCH	0172	F-5	7/32"	3/8"	4-1/2"	0.12	1

### 11 PC. PUNCH AND CHISEL KIT

The 11 tools in this set offer a broader range of sizes in our 4 basic struck tool categories: Cold Chisels, Solid Punches, Pin Punches and Center Punches. This set is popular with the professional, D.I.Y.'r and Industrial user. Packaged in a re-usable heavy duty pouch.

STOCK #0526



	Bulk Stk #	Description	Cut/Pt	Stock Size	Overall Length	Wt	Std. Pkg.
COLD CHISELS	0001	A-1	1/4"	3/16"	4"	0.02	1
	0007	A-3	3/8"	5/16"	5"	0.11	1
	0013	A-5	1/2"	7/16"	5-3/4"	0.25	1
	0016	A-6	5/8"	1/2"	6"	0.37	1
SOLID PUNCHES	0050	B-3	1/8"	5/16"	5"	0.10	1
	0059	B-6	3/16"	3/8"	5-1/2"	0.16	1
PIN PUNCHES	0079	C-2	3/32"	1/4"	4-1/2"	0.05	1
	0082	C-3	1/8"	5/16"	5"	0.08	1
	0088	C-5	5/32"	3/8"	5-1/2"	0.14	1
CENTER PUNCH	0091	C-6	3/16"	3/8"	5-1/2"	0.13	1
	0160	F-1	7/32"	3/8"	4-1/2"	0.13	1

**17 PC. PUNCH & CHISEL ROLL**

A slightly larger and more versatile roll than the 12 piece shown above. Still fits the toolbox, but it has 2 additional larger sized Cold Chisels, 1 more Solid Punch, 1 more Pin Punch and 2 additional Alignment Punches. Heavy duty vinyl and cloth roll-up pouch for easy access, organization, and storage.



STOCK #0535

	Bulk Stk #	Description	Cut/Pt	Stock Size	Overall Length	Wt	Std. Pkg.
COLD CHISELS	0004	A-2	5/16"	1/4"	4-1/2"	0.06	1
	0007	A-3	3/8"	5/16"	5"	0.11	1
	0013	A-5	1/2"	7/16"	5-3/4"	0.25	1
	0016	A-6	5/8"	1/2"	6"	0.37	1
	0019	A-7	3/4"	5/8"	7"	0.62	1
	SOLID PUNCHES	0047	B-2	3/32"	1/4"	4-1/2"	0.06
0053		B-4	1/8"	3/8"	5-1/2"	0.15	1
0056		B-5	5/32"	3/8"	5-1/2"	0.15	1
0059		B-6	3/16"	3/8"	5-1/2"	0.16	1
PIN PUNCHES		0079	C-2	3/32"	1/4"	4-1/2"	0.05
	0085	C-4	1/8"	3/8"	5-1/2"	0.13	1
	0091	C-6	3/16"	3/8"	5-1/2"	0.13	1
	0100	C-88	1/4"	7/16"	7"	0.33	1
ALIGNMENT PUNCHES	0120	D-6	5/32"	1/2"	10"	0.45	1
	0126	D-8	1/4"	3/4"	12"	1.18	1
CENTER PUNCH	0160	F-1	7/32"	3/8"	4-1/2"	0.13	1
PRICK PUNCH	0172	F-5	7/32"	3/8"	4-1/2"	0.12	1

**26 PC. PUNCH & CHISEL ROLL**

Our largest, finest, and most versatile tool roll! 26 of the world's finest struck tools...all in one heavy duty vinyl roll-up pouch for easy access, organization, and storage. Excellent for wall hanging in the shop or workplace. An excellent way to keep your struck tools organized...lets you find the right size when you need it. For the professional journeyman or serious DIY'R.

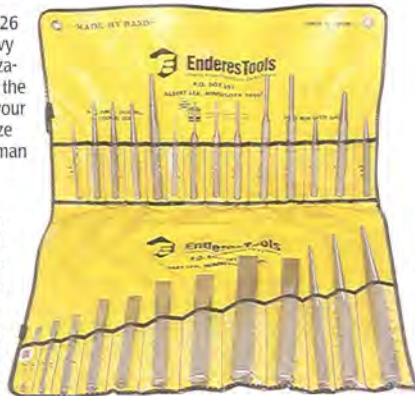

STOCK #0538

- 8 Cold Chisels
- 6 Pin Punches
- 5 Solid Punches
- 3 Alignment Punches
- 2 Center Punches
- 1 Rivet Buster
- 1 Prick Punch

	Bulk Stk #	Description	Cut/Pt	Stock Size	Overall Length	Wt	Std. Pkg.	
COLD CHISELS	0001	A-1	1/4"	3/16"	4"	0.02	1	
	0004	A-2	5/16"	1/4"	4-1/2"	0.06	1	
	0007	A-3	3/8"	5/16"	5"	0.11	1	
	0013	A-5	1/2"	7/16"	5-3/4"	0.25	1	
	0016	A-6	5/8"	1/2"	6"	0.37	1	
	0019	A-7	3/4"	5/8"	7"	0.62	1	
	0022	A-8	7/8"	3/4"	7-1/2"	0.90	1	
	0025	A-9	1"	7/8"	9"	1.52	1	
	RIVET BUSTER	0068	B-9	7/8"	3/4"	9"	1.12	1
		SOLID PUNCHES	0047	B-2	3/32"	1/4"	4-1/2"	0.02
	0053		B-4	1/8"	3/8"	5-1/2"	0.15	1
	0056		B-5	5/32"	3/8"	5-1/2"	0.15	1
	0059		B-6	3/16"	3/8"	5-1/2"	0.16	1
	0065		B-77	1/4"	1/2"	7"	0.35	1
PIN PUNCHES	0079	C-2	3/32"	1/4"	4-1/2"	0.05	1	
	0085	C-4	1/8"	3/8"	5-1/2"	0.13	1	
	0088	C-5	5/32"	3/8"	5-1/2"	0.14	1	
	0091	C-6	3/16"	3/8"	5-1/2"	0.13	1	
	0100	C-88	1/4"	7/16"	7"	0.33	1	
	0101	C-89	5/16"	1/2"	7"	0.33	1	
	ALIGNMENT PUNCHES	0120	D-6	5/32"	1/2"	10"	0.45	1
		0123	D-7	3/16"	5/8"	11"	0.77	1
0126		D-8	1/4"	3/4"	12"	1.18	1	
CENTER PUNCHES	0160	F-1	7/32"	3/8"	4-1/2"	0.13	1	
	0164	F-2A	17/64"	1/2"	4-1/2"	0.77	1	
PRICK PUNCH	0172	F-5	7/32"	3/8"	4-1/2"	0.12	1	

**#99 COUNTER DISPLAY**

**99 Total Tools** - This new display combines the most popular selling items from the 128 Display and the 20 Display; which have reduced SKU count 2 of each item; with the exception of the Cutting Nippers which remain at 1 each. All these items displayed in a eye catching light weight plastic merchandiser. Display measures 19" long x 12" deep.



#99 COUNTER DISPLAY  
STOCK #0519

#99 COUNTER DISPLAY  
(BOARD ONLY)  
STOCK #0520

	Bulk Stk #	Description	Cut/Pt	Stock Size	Overall Length	Wt	Std. Pkg.	
COLD CHISELS	0001	A-1	1/4"	3/16"	4"	0.02	2	
	0004	A-2	5/16"	1/4"	4-1/2"	0.06	2	
	0007	A-3	3/8"	5/16"	5"	0.11	2	
	0010	A-4	7/16"	3/8"	5-1/2"	0.17	2	
	0013	A-5	1/2"	7/16"	5-3/4"	0.25	2	
	0016	A-6	5/8"	1/2"	6"	0.37	2	
	0019	A-7	3/4"	5/8"	7"	0.62	2	
	0022	A-8	7/8"	3/4"	7-1/2"	0.90	2	
	0025	A-9	1"	7/8"	9"	1.52	2	
	0014	A-14	1/2"	7/16"	12"	0.55	2	
	0028	A-10	5/8"	1/2"	12"	0.71	2	
	0031	A-11	3/4"	5/8"	12"	1.11	2	
	0033	A-17	7/8"	3/4"	12"	1.53	2	
	0037	A-13	1"	7/8"	12"	1.07	2	
	SOLID PUNCHES	0044	B-1	1/16"	3/16"	4"	0.02	2
		0047	B-2	3/32"	1/4"	4-1/2"	0.06	2
		0050	B-3	1/8"	5/16"	5"	0.10	2
0059		B-6	3/16"	3/8"	5-1/2"	0.16	2	
0065		B-77	1/4"	1/2"	7"	0.35	2	
0067		B-8	3/8"	5/8"	9"	0.72	2	
PIN PUNCHES		0076	C-1	1/16"	3/16"	4"	0.02	2
		0079	C-2	3/32"	1/4"	4-1/2"	0.05	2
		0082	C-3	1/8"	5/16"	5"	0.08	2
		0091	C-6	3/16"	3/8"	5-1/2"	0.13	2
ALIGNMENT PUNCHES	0094	C-7	13/64"	7/16"	6"	0.21	2	
	0097	C-8	3/16"	1/2"	7"	0.28	2	
	0100	C-88	1/4"	7/16"	7"	0.33	2	
	0102	C-9	3/8"	5/8"	9"	0.68	2	
	0117	D-5	1/8"	3/8"	9"	0.21	2	
	0120	D-6	5/32"	1/2"	10"	0.45	2	
	0123	D-7	3/16"	5/8"	11"	0.77	2	
	0126	D-8	1/4"	3/4"	12"	1.18	2	
	0127	D-88	5/16"	3/4"	14"	1.47	2	
	CENTER PUNCHES	0160	F-1	7/32"	3/8"	4-1/2"	0.13	2
0163		F-2	17/64"	1/2"	4-1/2"	0.23	2	
0166		F-3	7/32"	3/8"	5-1/2"	0.17	2	
PRICK PUNCHES	0159	F-26	1/8"	5/16"	5"	0.06	2	
	0175	F-6	7/32"	3/8"	5-1/2"	0.17	2	
WOOD & STEEL CHISELS	0171	F-29	1/8"	5/16"	5"	0.06	2	
	0152	E-8	1"	1/2"	10"	0.55	2	
STAR DRILLS	0186	F-9	1/2"	3/8"	12"	0.38	2	
	0192	F-11	3/4"	5/8"	12"	1.02	2	
HOOF NIPPER	0387	F12			14"	1		
CUTTING NIPPERS	0375	B-10			10"	1.02	1	
	0381	C-10			14"	1.65	1	
RIVET BUSTER	0068	B-9	7/8"	3/4"	9"	1.12	2	
BRICK SETS	0340	B-14	3"		7"	2		
	0341	B-20	3-1/2"		7"	2		
	0342	B-26	4"		7"	2		
MASON CHISEL	0343	B-15	2-1/4"		7-1/2"	2		
FLOOR CHISEL	0352	B-18	2-3/4"		12"	2		

## # 128 COUNTER DISPLAY

**JUST ONE TURN PER YEAR . . .**

*will earn you a profit of over \$240.00 per square foot!*

**Only 18" LONG x 12" DEEP . . . Displays 127 tools!**

In developing this counter/shelf display, Enderes Tool® Company researched the marketplace for the 52 individual tools that we could take to any store throughout the country and assure that the tools in the display will sell in that area. 52 fast selling, fast turn struck tools. Gets the tools off the wall and out of bins. Stand-up tool merchandising in the most compact style. An absolute must for anyone marketing struck tools.



#128 COUNTER DISPLAY  
STOCK #0541

#128 COUNTER DISPLAY  
(BOARD ONLY)  
STOCK #0542

	Bulk Stk #	Description	Cut/Pt	Stock Size	Overall Length	Wt	Std. Pkg.	
COLD CHISELS	0001	A-1	1/4"	3/16"	4"	0.02	3	
	0004	A-2	5/16"	1/4"	4-1/2"	0.06	3	
	0007	A-3	3/8"	5/16"	5"	0.11	3	
	0010	A-4	7/16"	3/8"	5-1/2"	0.17	3	
	0013	A-5	1/2"	7/16"	5-3/4"	0.25	3	
	0016	A-6	5/8"	1/2"	6"	0.37	3	
	0019	A-7	3/4"	5/8"	7"	0.62	3	
	0022	A-8	7/8"	3/4"	7-1/2"	0.90	3	
	0025	A-9	1"	7/8"	9"	1.52	2	
	0014	A-14	1/2"	7/16"	12"	0.55	2	
	0028	A-10	5/8"	1/2"	12"	0.71	2	
	0031	A-11	3/4"	5/8"	12"	1.11	2	
	0033	A-17	7/8"	3/4"	12"	1.53	2	
	0037	A-13	1"	7/8"	12"	1.07	2	
SOLID PUNCHES	0044	B-1	1/16"	3/16"	4"	0.02	2	
	0047	B-2	3/32"	1/4"	4-1/2"	0.06	2	
	0050	B-3	1/8"	5/16"	5"	0.10	2	
	0059	B-6	3/16"	3/8"	5-1/2"	0.16	2	
	0065	B-77	1/4"	1/2"	7"	0.35	2	
	0066	B-78	5/16"	1/2"	7"	0.36	2	
	0067	B-8	3/8"	5/8"	9"	0.72	2	
	0076	C-1	1/16"	3/16"	4"	0.02	3	
PIN PUNCHES	0079	C-2	3/32"	1/4"	4-1/2"	0.05	3	
	0082	C-3	1/8"	5/16"	5"	0.08	3	
	0091	C-6	3/16"	3/8"	5-1/2"	0.13	3	
	0094	C-7	13/64"	7/16"	6"	0.21	3	
	0097	C-8	3/16"	1/2"	7"	0.28	3	
	0100	C-88	1/4"	7/16"	7"	0.33	3	
	0101	C-89	5/16"	1/2"	7"	0.33	2	
	0102	C-9	3/8"	5/8"	9"	0.68	2	
	ALIGNMENT PUNCHES	0117	D-5	1/8"	3/8"	9"	0.21	3
		0120	D-6	5/32"	1/2"	10"	0.45	3
0123		D-7	3/16"	5/8"	11"	0.77	3	
0126		D-8	1/4"	3/4"	12"	1.18	3	
0127		D-88	5/16"	3/4"	14"	1.47	2	
CENTER PUNCHES	0160	F-1	7/32"	3/8"	4-1/2"	0.13	3	
	0163	F-2	17/64"	1/2"	4-1/2"	0.23	3	
	0166	F-3	7/32"	3/8"	5-1/2"	0.17	3	
	0159	F-26	1/8"	5/16"	5"	0.06	3	
PRICK PUNCHES	0172	F-5	7/32"	3/8"	4-1/2"	0.12	3	
	0175	F-6	7/32"	3/8"	5-1/2"	0.17	3	
	0171	F-29	1/8"	5/16"	5"	0.06	3	
WOOD & STEEL CHISELS	0149	E-7	3/4"	7/16"	9"	0.38	2	
	0152	E-8	1"	1/2"	10"	0.55	2	
	0155	E-9	1-1/4"	5/8"	11"	0.97	2	
STAR DRILLS	0186	F-9	1/2"	3/8"	12"	0.38	2	
	0189	F-10	5/8"	1/2"	12"	0.66	2	
	0192	F-11	3/4"	5/8"	12"	1.02	2	
HOOF NIPPER	0387	F-12		14"	1.60	1		
CUTTING NIPPERS	0375	B-10		10"	1.02	1		
	0381	C-10		14"	1.65	1		
RIVET BUSTER	0068	B-9	7/8"	3/4"	9"	1.12	2	

## # 234 COUNTER DISPLAY

**A BEAUTIFUL MERCHANDISER!**

*Just one turn per year will earn you a profit of over \$270.00 per square foot!*

**36" LONG x 10" DEEP . . . 2.5 square feet**

41 different tools in this display...all proven sellers! Featured in this stand up merchandising concept, this display is not only compact, but also gets struck tools off the wall and out of bulk bins. Makes re-ordering easy and creates a massive appearance for your tool department. Displays and inventories 6 of each tool with the exception of the 3 Cutting Nippers and the 3 longest Cold Chisels.

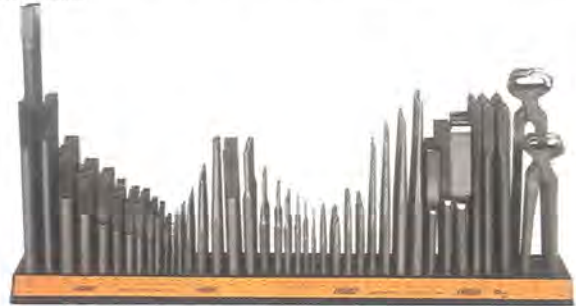

#234 COUNTER DISPLAY - STOCK #0593

#234 COUNTER DISPLAY  
(BOARD ONLY) - STOCK #0594

	Bulk Stk #	Description	Cut/Pt	Stock Size	Overall Length	Wt	Std. Pkg.	
COLD CHISELS	0001	A-1	1/4"	3/16"	4"	0.02	6	
	0004	A-2	5/16"	1/4"	4-1/2"	0.06	6	
	0007	A-3	3/8"	5/16"	5"	0.11	6	
	0010	A-4	7/16"	3/8"	5-1/2"	0.17	6	
	0013	A-5	1/2"	7/16"	5-3/4"	0.25	6	
	0016	A-6	5/8"	1/2"	6"	0.37	6	
	0019	A-7	3/4"	5/8"	7"	0.62	6	
	0022	A-8	7/8"	3/4"	7-1/2"	0.90	6	
	0025	A-9	1"	7/8"	9"	1.52	6	
	0028	A-10	5/8"	1/2"	12"	0.71	6	
	0031	A-11	3/4"	5/8"	12"	1.11	3	
	0034	A-12	7/8"	3/4"	18"	2.30	3	
	SOLID PUNCHES	0044	B-1	1/16"	3/16"	4"	0.02	6
		0047	B-2	3/32"	1/4"	4-1/2"	0.06	6
0053		B-4	1/8"	3/8"	5-1/2"	0.15	6	
0062		B-7	3/16"	1/2"	7"	0.32	6	
0067		B-8	3/8"	5/8"	9"	0.72	6	
0076		C-1	1/16"	3/16"	4"	0.02	6	
0079		C-2	3/32"	1/4"	4-1/2"	0.05	6	
0082		C-3	1/8"	5/16"	5"	0.08	6	
PIN PUNCHES	0091	C-6	3/16"	3/8"	5-1/2"	0.13	6	
	0094	C-7	13/64"	7/16"	6"	0.21	6	
	0097	C-8	3/16"	1/2"	7"	0.28	6	
	0102	C-9	3/8"	5/8"	9"	0.68	6	
	CENTER PUNCHES	0160	F-1	7/32"	3/8"	4-1/2"	0.13	6
		0163	F-2	17/64"	1/2"	4-1/2"	0.23	6
		0166	F-3	7/32"	3/8"	5-1/2"	0.17	6
	PRICK PUNCH	0175	F-6	7/32"	3/8"	4-1/2"	0.17	6
		0186	F-9	1/2"	3/8"	12"	0.38	6
	STAR DRILLS	0189	F-10	5/8"	1/2"	12"	0.66	6
0192		F-11	3/4"	5/8"	12"	1.02	6	
ALIGNMENT PUNCHES		0117	D-5	1/8"	3/8"	9"	0.21	6
	0120	D-6	5/32"	1/2"	10"	0.45	6	
	0123	D-7	3/16"	5/8"	11"	0.77	6	
	0126	D-8	1/4"	3/4"	12"	1.18	6	
	0149	E-7	3/4"	7/16"	9"	0.38	6	
WOOD & STEEL CHISELS	0152	E-8	1"	1/2"	10"	0.55	6	
	0155	E-9	1-1/4"	5/8"	11"	0.97	6	
	CUTTING NIPPERS	0375	B-10		10"	1.02	3	
0381		C-10		14"	1.65	3		
RIVET BUSTER	0068	B-9	7/8"	3/4"	9"	1.12	6	

**PHONE: 800-874-7776**

**FAX: 507-373-2398**

The same proven successful stand-up merchandising concept. So compact, so easy to re-order from. Carries your entire inventory right in the display. And don't overlook the massive appearance this display brings to your tool department. 55 different tools; 23 in 3's and 32 in 6's.

	Bulk Stk #	Description	Cut/Pt	Stock Size	Overall Length	Wt	Std. Pkg.
<b>COLD CHISELS</b>	0001	A-1	1/4"	3/16"	4"	0.02	6
	0004	A-2	5/16"	1/4"	4-1/2"	0.06	6
	0007	A-3	3/8"	5/16"	5"	0.11	6
	0010	A-4	7/16"	3/8"	5-1/2"	0.17	6
	0013	A-5	1/2"	7/16"	5-3/4"	0.25	6
	0016	A-6	5/8"	1/2"	6"	0.37	6
	0019	A-7	3/4"	5/8"	7"	0.62	6
	0022	A-8	7/8"	3/4"	7-1/2"	0.90	6
	0025	A-9	1"	7/8"	9"	1.52	6
	0014	A-14	1/2"	7/16"	12"	0.55	3
	0031	A-11	3/4"	5/8"	12"	1.11	3
	0033	A-17	7/8"	3/4"	12"	1.53	3
	0037	A-13	1"	7/8"	12"	2.07	3
	0028	A-10	5/8"	1/2"	12"	0.71	3
	0032	A-16	3/4"	5/8"	18"	1.66	3
	0034	A-12	7/8"	3/4"	18"	2.30	3
	0039	A-18	1"	7/8"	18"	3.20	3
	<b>SOLID PUNCHES</b>	0044	B-1	1/16"	3/16"	4"	0.02
0047		B-2	3/32"	1/4"	4-1/2"	0.06	6
0050		B-3	1/8"	5/16"	5"	0.10	6
0059		B-6	3/16"	3/8"	5-1/2"	0.16	6
0065		B-77	1/4"	1/2"	7"	0.35	6
0066		B-78	5/16"	1/2"	7"	0.36	3
0067		B-8	3/8"	5/8"	9"	0.72	3
<b>PIN PUNCHES</b>		0076	C-1	1/16"	3/16"	4"	0.02
	0079	C-2	3/32"	1/4"	4-1/2"	0.05	6
	0082	C-3	1/8"	5/16"	5"	0.08	6
	0088	C-5	5/32"	3/8"	5-1/2"	0.14	6
	0091	C-6	3/16"	3/8"	5-1/2"	0.13	6
	0094	C-7	13/64"	7/16"	6"	0.21	6
	0100	C-88	1/4"	7/16"	7"	0.33	6
	0101	C-89	5/16"	1/2"	7"	0.33	3
	0102	C-9	3/8"	5/8"	9"	0.68	3

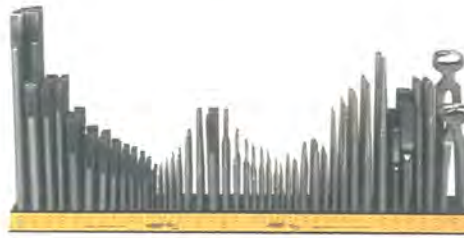

#258 COUNTER DISPLAY  
STOCK #0566

#258 COUNTER DISPLAY  
(BOARD ONLY) STOCK #0567

	Bulk Stk #	Description	Cut/Pt	Stock Size	Overall Length	Wt	Std. Pkg.
<b>ALIGNMENT PUNCHES</b>	0117	D-5	1/8"	3/8"	9"	0.21	6
	0120	D-6	5/32"	1/2"	10"	0.45	6
	0123	D-7	3/16"	5/8"	11"	0.77	6
	0126	D-8	1/4"	3/4"	12"	1.18	6
<b>CENTER PUNCHES</b>	0127	D-88	5/16"	3/4"	14"	1.47	3
	0128	D-89	3/8"	3/4"	14"	1.53	3
	0160	F-1	7/32"	3/8"	4-1/2"	0.13	6
	0164	F-2A	17/64"	1/2"	6"	0.33	6
<b>PRICK PUNCHES</b>	0168	F-27	1/2"	5/8"	6"	0.52	6
	0159	F-26	1/8"	5/16"	5"	0.06	6
	0175	F-6	7/32"	3/8"	4-1/2"	0.17	6
<b>WOOD &amp; STEEL CHISELS</b>	0146	E-6	1/2"	3/8"	8"	0.23	3
	0149	E-7	3/4"	7/16"	9"	0.38	3
	0152	E-8	1"	1/2"	10"	0.55	3
<b>STAR DRILLS</b>	0155	E-9	1-1/4"	5/8"	11"	0.97	3
	0183	F-8	3/8"	5/16"	12"	0.26	3
	0186	F-9	1/2"	3/8"	12"	0.38	3
	0189	F-10	5/8"	1/2"	12"	0.66	3
<b>CUTTING NIPPERS</b>	0192	F-11	3/4"	5/8"	12"	1.02	3
	0375	B-10			10"	1.02	3
<b>RIVET BUSTER</b>	0381	C-10			14"	1.65	3
	0068	B-9	7/8"	3/4"	9"	1.12	6

**STRUCK TOOL CENTER**

An attractive and compact merchandiser designed to display the highest volume, highest profit products within the Struck Hand Tool category. Each product comes complete with UPC code and product use descriptions. 90 total pieces, 30 different products. 3 of each SKU. Tool hangers included. Gives your customers an excellent selection.



CD STRUCK TOOL CENTER  
WATERFALL MERCHANDISER  
STOCK #0898

CD STRUCK TOOL CENTER  
WATERFALL MERCHANDISER (RACK ONLY)  
STOCK #8175



CD STRUCK TOOL CENTER  
MERCHANDISER  
STOCK #0897

CD STRUCK TOOL CENTER  
MERCHANDISER (RACK ONLY)  
STOCK #8160

	Cd Stk #	Description	Cut/Pt	Stock Size	Overall Length	Wt	Std. Pkg.
<b>Cold Chisels</b>	0600	A-1	1/4"	3/16"	4"	0.05	3
	0603	A-2	5/16"	1/4"	4-1/2"	0.08	3
	0606	A-3	3/8"	5/16"	5"	0.13	3
	0612	A-5	1/2"	7/16"	5-3/4"	0.27	3
	0615	A-6	5/8"	1/2"	6"	0.36	3
	0618	A-7	3/4"	5/8"	7"	0.65	3
	0621	A-8	7/8"	3/4"	7-1/2"	0.93	3
	0622	A-9	1"	7/8"	9"	0.93	3
	<b>Flat Brick Chisel</b>	0282	B-27	1-1/8"	7/8"	12"	1.07
<b>Solid Punches</b>	0630	B-1	1/16"	3/16"	4"	0.05	3
	0639	B-4	1/8"	3/8"	5-1/2"	0.17	3
	0645	B-6	3/16"	3/8"	5-1/2"	0.18	3
	0649	B-77	1/4"	1/2"	7"	0.38	3
<b>Pin Punches</b>	0655	C-1	1/16"	3/16"	4"	0.05	3
	0661	C-3	1/8"	5/16"	5"	0.11	3
	0664	C-4	1/8"	3/8"	5-1/2"	0.16	3
	0668	C-6	3/16"	3/8"	5-1/2"	0.16	3
	0674	C-88	1/4"	7/16"	7"	0.28	3

	Cd Stk #	Description	Cut/Pt	Stock Size	Overall Length	Wt	Std. Pkg.	
<b>Prick Punches</b>	0768	F-5	7/32"	3/8"	4-1/2"	0.15	3	
	0771	F-6	7/32"	3/8"	5-1/2"	0.50	3	
	0766	F-29	1/8"	5/16"	5"	0.08	3	
<b>Center Punches</b>	0753	F-1	7/32"	3/8"	4-1/2"	0.16	3	
	0756	F-2	17/64"	1/2"	4-1/2"	0.26	3	
	0751	F-25	1/8"	1/4"	4-1/2"	0.08	3	
	0752	F-26	1/8"	5/16"	5"	0.08	3	
<b>Alignment Punch</b>	0718	D-7	3/16"	5/8"	11"	0.77	3	
<b>Nail Sets</b>	0754	NS1	1/32"	3/8"	4"	0.20	3	
	0757	NS2	2/32"	3/8"	4"	0.20	3	
	0760	NS3	3/32"	3/8"	4"	0.20	3	
	0761	Combo Kit includes one each of 1/32", 2/32", 3/32".					0.80	3

# WILL YOUR TOOLS STAND THIS TEST? ENDERES® WILL!



ACTUAL UNTOUCHED PHOTO -  
ENDERES® TOOLS THROUGH  
1/4" ANGLE IRON!

**TRUTHFULLY,**  
don't you hate buying "bargain price" tools that never seem to complete their intended job?

**REMEMBER,**  
price is forgotten when a tool fails to hold an edge, chips or breaks. Even if you never put your tools through a test like 1/4" Angle Iron, isn't it nice to know the quality is there for the tough jobs. Especially when it costs just a few cents more.

**ENDERES TOOL® GUARANTEES . . .**  
all their tools to out perform the others. We give a full replacement guarantee if one ever fails its designed function. So, when spending money on Struck Tools, spend it wisely . . .

**BUY ENDERES®!!!**

For over 100 years, the employees manufacturing Enderes Tools have dedicated themselves to manufacturing only the finest quality tools available on the market today.

In November 2012 we re-opened as Northbridge Tool LLC under new management with a renewed commitment to customer service and quality. We are proud to say that we were able to hire back almost all of the employees in the manufacturing plant including the plant manager. They are all highly skilled, well trained, very conscientious employees with over 200 years of combined experience in the forging and heat treating of metal tools.

At Enderes Tools, we feature a unique manufacturing process in which each tool is individually heat treated to produce an edge that is unsurpassed for keenness and durability. Should the working edge ever become dull from repeated use, the process allows the tools to be re-sharpened with a common file, in accordance with all of the latest safety standards.

We know that you have many choices when purchasing your hand tools. We ask only for the opportunity to earn your business with the unsurpassed quality of our "Made in the USA" Enderes brand tools.

Steven R Overgaard  
President, C.E.O.  
Northbridge Tool, LLC  
Albert Lea, Mn



HERE IS A SAMPLING OF OUR FASTEST SELLING ITEMS, DISPLAYED ON THEIR NEW ATTENTION GRABBING CARDS AND MERCHANDISERS . . .

**EnderesTools** PROFESSIONAL QUALITY  
**STRUCK TOOL CENTER**



**EnderesTools** PROFESSIONAL QUALITY  
**SCREWDRIVERS**



**EnderesTools** PROFESSIONAL QUALITY  
**MULTI-BIT SCREWDRIVERS**



**EnderesTools** PROFESSIONAL QUALITY  
**MASON'S TOOLS**



**EnderesTools** PROFESSIONAL QUALITY  
**STARTING & PIN PUNCHES**



**EnderesTools** Industry's Finest Quality  
**CONSTRUCTION BARS**



**EnderesTools** PROFESSIONAL QUALITY  
**COLD CHISELS**



**EnderesTools** PROFESSIONAL QUALITY  
**"STRIKE-GUARD" TOOL CENTER**



**EnderesTools** PROFESSIONAL QUALITY  
**NAIL SETS**



Northbridge Tool, LLC  
SALES & CORPORATE OFFICE  
924 East 14<sup>th</sup> St  
Albert Lea, MN 56007  
Phone: 507-373-2398  
800-874-7776  
Fax: 507-373-2398  
www.enderes.com

**EnderesTools**  
Quality Forged Hand Tools For a Lifetime

MANUFACTURING PLANT  
14 & Railroad  
Jobs Industrial Park  
Albert Lea, MN 56007  
Phone: 507-373-2396  
Fax: 507-373-2398